

No.	REVISION	BY	DATE	AUTH
A	DRAFT COPY			
0	ISSUED	P.M.	3/2007	

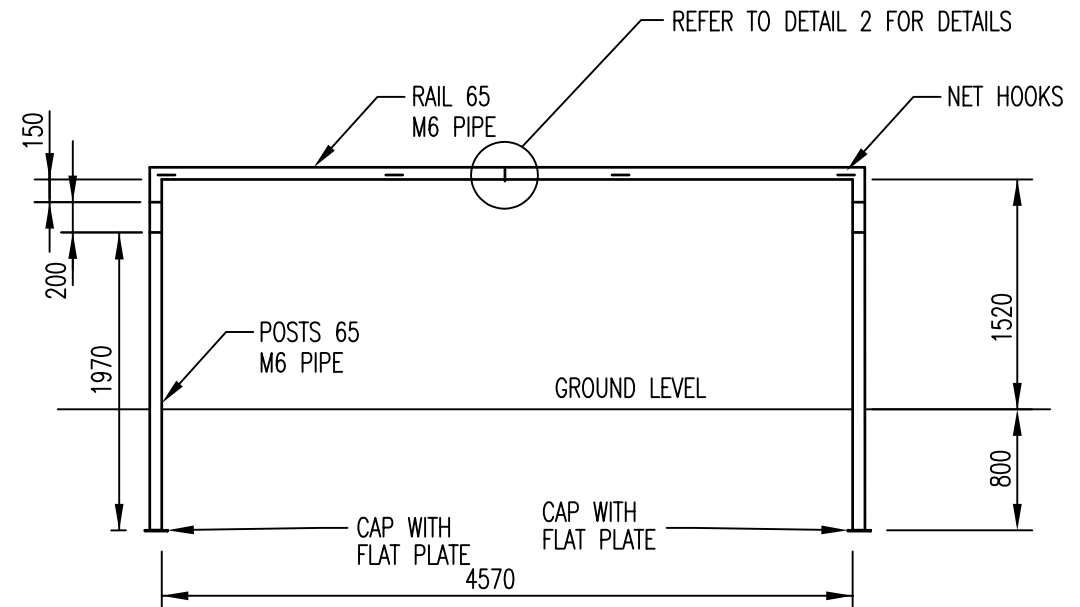

ELEVATION

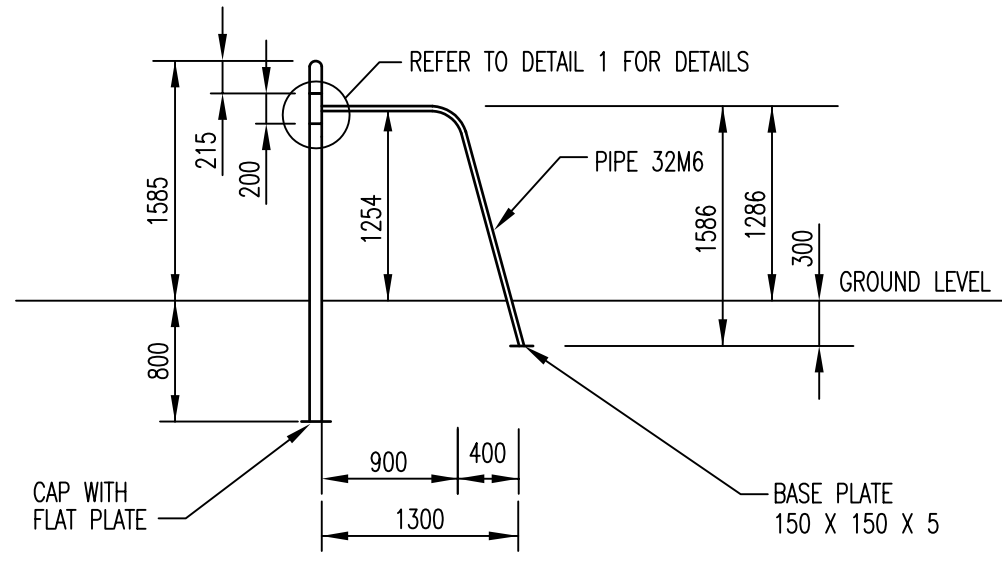

END ELEVATION

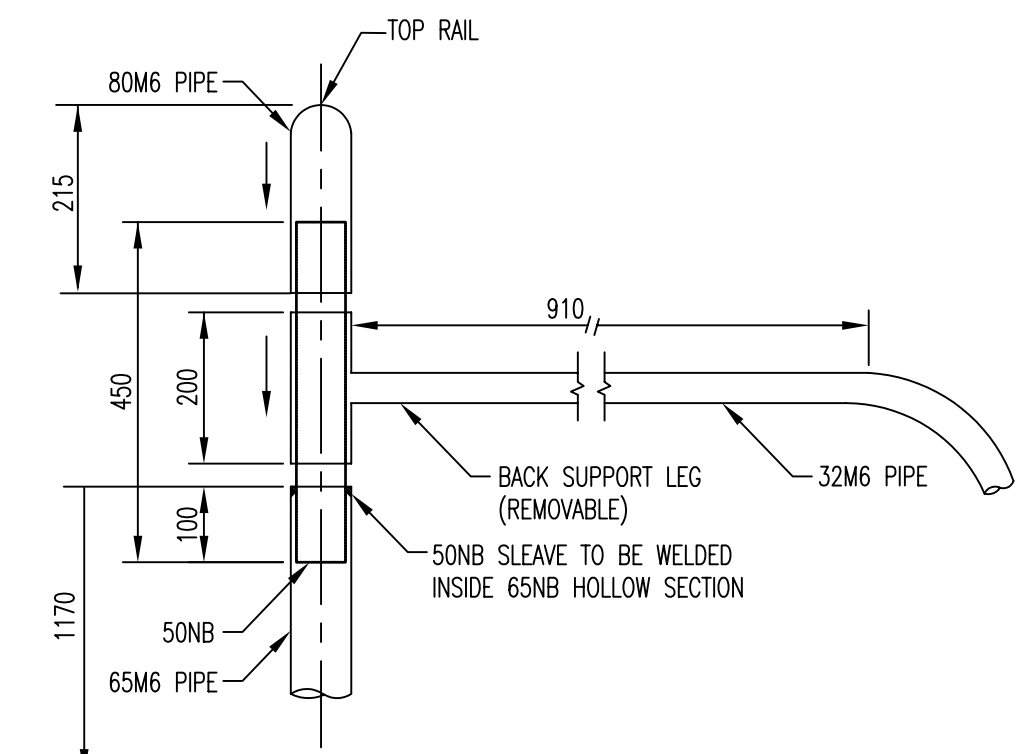

DETAIL 1
(NOT TO SCALE)

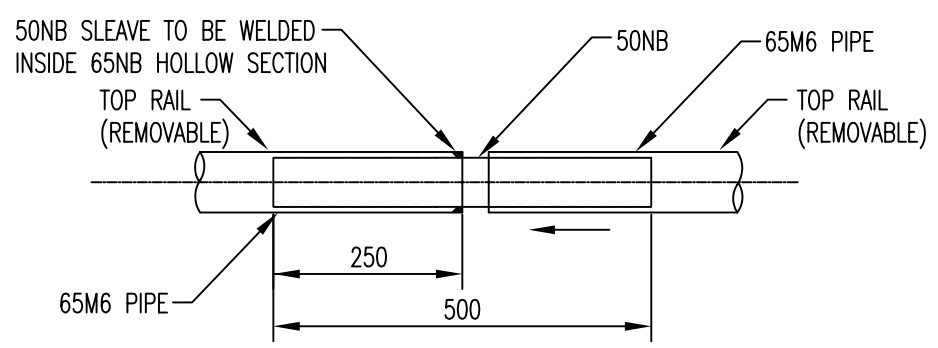

DETAIL 2
(NOT TO SCALE)

NOTES:

1. ALL MEASUREMENTS IN MILLIMETERS.
2. FOUR POSTS AND TWO RAILS PER SET OF 65 M6 DIAMETER PIPE NOMINAL BORE 3.6MM THICKNESS OF WALL.
3. FOUR BACK STRUTS PER SET OF 32M6 DIAMETER PIPE.
4. BACK STRUT SLEEVES TO BE FREE OF WELDING AND CUTTING BURS ON THE INSIDE.
5. POSTS AND STRUTS ARE TO HAVE CAPS WELDED ONTO THEIR ENDS.
6. STRUTS TO HAVE 150x150x5 BASE PLATES WELDED ONTO THEIR ENDS.
7. ALL WELDS TO BE COATED WITH COLD GALVANIZING PAINT.
8. SPIGOTS TO BE SEAL WELDED TO POSTS ONLY.
9. ALL EXPOSED SURFACES TO BE POWDER COATED WHITE

*INDICATES SIGNATURE ON ORIGINAL ISSUE OF DRAWING.

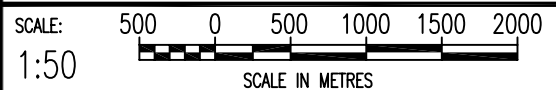

DATUM:	GRID:
LOCAL	LOCAL

SPORTING EQUIPMENT

TRANSPORTABLE SOCCER GOALS
CONSTRUCTION DETAILS
UNDER EIGHT'S

STANDARD
SHEET 1 OF 3

CITY OF WANNEROO
INFRASTRUCTURE



SURVEYED:	CHECKED:
/ / 2007	* PAUL WHITE 27/03/2007 COORDINATOR PARKS MAINTENANCE
DESIGNED:	AUTHORISED:
C.O.W. / / 2007	* ALAN MILLARD 28/03/2007 MANAGER INFRASTRUCTURE MAINTENANCE
DRAWN:	APPROVED:
C.O.W. / / 2007	* DENNIS BLAIR 30/03/2007 DIRECTOR INFRASTRUCTURE

FILE No.	DRAWING No.	SHEET	REVISION	ORIGINAL DRG. SIZE
PROJECT No.	TS 30-10-0			A3