

# Code of Practice for the Reuse of Greywater in Western Australia

January 2005





# Code of Practice for the Reuse of Greywater in Western Australia

January 2005



Department of Environment  
Department of Health



*This page is intentionally left blank*



## FOREWORD

Western Australia is experiencing water restrictions due to current drought conditions and the critically low levels of surface water storage. It is recognised that in times such as these many householders like to conserve water by reusing their greywater. The objective of this Code of Practice (the Code) is to assist in the promotion of acceptable greywater reuse practices and promote conservation of our quality ground and surface water supplies.

This Code of Practice was developed from draft guidelines released for public comment in July 2002. Comments from the public, where considered applicable, have been incorporated into this document. The final Code was prepared by the Department of Health in consultation with various stakeholders including the Water Corporation, Department of Environment and Environmental Health Officers from the following Local Governments: Bassendean, Cambridge, Gosnells, Mandurah, Melville and Stirling.

The Code, which was prepared by the Environmental Health Directorate of the Department of Health, is published by the Executive Director, Public Health under the provisions of section 344(2) of the *Health Act 1911*, and is to be read in conjunction with the *Health (Treatment of Sewage and Disposal of Effluent and Liquid Waste) Regulations 1974*.

Further copies of the Code are available on the Department of Health website at <http://www.health.wa.gov.au>.



## TABLE OF CONTENTS

<b>PART 1 – GENERAL INFORMATION</b>	<b>1</b>
1.1 INTRODUCTION	2
1.2 DEFINITIONS	4
1.3 ABBREVIATIONS	7
1.4 CHARACTERISTICS OF HOUSEHOLD GREYWATER	7
1.4.1 Household Water Usage Volumes	8
1.4.2 Composition of Household Greywater	9
1.5 HEALTH AND SAFETY REQUIREMENTS	10
1.6 ENVIRONMENTAL REQUIREMENTS	11
<b>PART 2 – HOMEOWNER’S GUIDE TO REUSING GREYWATER</b>	<b>15</b>
2.1 REDUCING WATER USAGE	16
2.2 WHAT CAN I DO TO REUSE MY GREYWATER?	16
2.2.1 How can I reuse greywater via a bucket?	16
2.2.2 Installing an approved greywater system	17
2.3 GREYWATER SYSTEMS APPROVED FOR USE	18
2.4 INSTANCES WHERE GREYWATER REUSE IS NOT PERMITTED	19
2.5 PROCEDURE FOR OBTAINING A PERMIT TO INSTALL A GREYWATER SYSTEM	19
2.5.1 Application	20
2.5.2 Installing a System	21
2.6 SYSTEM MAINTENANCE	21
<b>PART 3 – INFORMATION FOR GREYWATER SYSTEM DESIGNERS AND LOCAL GOVERNMENT</b>	<b>23</b>
3.1 DESIGN AND PERFORMANCE REQUIREMENTS	24
3.2 GREYWATER SYSTEM OPTIONS	27
3.2.1 Manual bucketing of greywater	27
3.2.2 Primary Treatment Systems	28
3.2.3 Secondary Treatment Systems	28
3.2.4 Other Treatment Systems	28
3.3 GREYWATER IRRIGATION OPTIONS	29
3.4 DESIGNING A GREYWATER SYSTEM	31
3.4.1 General	31
3.4.2 Calculating Greywater Quantities	31
3.4.3 Sizing Greywater Tanks	32
3.4.4 Sizing Irrigation Areas	33
3.4.5 Reduced Sizing Allowances	34
3.5 SITING A GREYWATER IRRIGATION SYSTEM	36
3.6 MATERIALS FOR IRRIGATION AREAS	38



<b>CONTACTS</b>	<b>39</b>
<b>REFERENCES</b>	<b>40</b>
<b>BIBLIOGRAPHY</b>	<b>41</b>
<b>FIGURES</b>	
Figure 1: Household Water Usage	8
Figure A5: 1 – Self Supported Arch	49
Figure A5: 2 – Evapo-transpiration-absorption (ETA) trench/Evapo-transpiration-seepage (ETS) trench	50
Figure A5: 3 – ETA/ETS Bed	50
Figure A5: 4 – Conventional Piped Trench	51
Figure A5: 5 – Conventional Bed	51
Figure A5: 6 – Typical layout of sub-surface irrigation	52
<b>TABLES</b>	
Table 1: Faecal Coliform Numbers in Greywater prior to storage	9
Table 2: Typical Composition of Greywater compared with Raw Sewage	10
Table 3: Greywater Irrigation Options according to Treatment	29
Table 4: Daily Domestic Greywater Volumes	32
Table 5: Standard Greywater Loading Infiltration Rates	34
Table 6: Trench Lengths for a 200mm x 200mm trench using the standard LIR or a higher (double) LIR	35
Table 7: Minimum Setback Distances	37
<b>APPENDICES</b>	
Appendix 1 – Guidelines for the Bucketing of Greywater	42
Appendix 2 – Examples of Greywater Calculations	44
Appendix 3 – Primary Treatment Systems	46
Appendix 4 – Secondary Treatment Systems	48
Appendix 5 – Sub-soil Trench Irrigation	49



*This page is intentionally left blank*



# PART 1

# GENERAL INFORMATION

## PART 1

1.1	INTRODUCTION	2
1.2	DEFINITIONS	4
1.3	ABBREVIATIONS	7
1.4	CHARACTERISTICS OF HOUSEHOLD GREYWATER	7
1.5	HEALTH AND SAFETY REQUIREMENTS	10
1.6	ENVIRONMENTAL REQUIREMENTS	11



## PART 1. GENERAL INFORMATION

### 1.1 INTRODUCTION

Domestic wastewater is made up of 'greywater' and 'blackwater'.

- 'Greywater' is the wastewater generated from bathrooms, kitchens and laundries.
- 'Blackwater' is the wastewater generated from toilets and is contaminated with faeces and urine.

The opportunity exists for greywater to be reused to irrigate gardens. This will reduce the demand on quality ground and surface water supplies. Considering the dry environment in many parts of Western Australia and the sometimes limited supply of water, it is important that water is used efficiently and conserved wherever possible. Reuse of greywater is therefore supported and encouraged by Government to help conserve water.

However, this has to be accomplished without compromising public health, causing unacceptable environmental impact, or downgrading the amenity of our residential areas. Greywater must be reused in a beneficial manner for landscaping (i.e. at the plant's rootzone) rather than just being disposed of at a depth, which would not benefit plants.

Greywater can contain pathogenic microorganisms including bacteria, protozoa, viruses and parasites in concentrations high enough to present a health risk. Therefore, a level of caution must be exercised with greywater reuse. This can be achieved by preventing unnecessary human contact with greywater, or by treating the greywater to remove or destroy the microorganisms.

Greywater also contains oils, fats, detergents, soaps, nutrients, salts and particles of hair, food and lint, which can impact on operational performance and life of a greywater irrigation system. If these contaminants aren't managed correctly they can degrade soil structure, clog groundwater flow paths, escape to the ground surface or even cause non-wetting characteristics in garden soils.

A clear understanding of the potential health risks, operational problems and environmental impacts that can be caused by improperly designed greywater treatment and land application systems is necessary to ensure only suitably designed greywater treatment and land application systems are used. There will be a cost to design, install and maintain such greywater systems if they are to protect public health and be environmentally sustainable. Greywater systems should be designed for long term use. Past experiences have shown that some poorly developed greywater systems will result in clogging of the soil, odours, blockages and become a burden (financial and time) due to constant maintenance requirements.



The objective of this Code is to assist in the promotion of acceptable long term greywater reuse practice and promote conservation of our quality ground and surface water supplies by:

- establishing acceptable means of greywater reuse as a guide for local government, industry and homeowners;
- setting minimum design and installation standards and procedures for gaining approval for greywater system installations;
- safeguarding the community from possible disease transmission arising from improper greywater reuse; and
- ensuring that greywater installations are designed, installed and operated so that when used in households on a long term basis they;
  - do not harm the environment,
  - do not cause a nuisance, and
  - are appropriately sited and maintained to a satisfactory standard.

This document considers reuse of greywater in residential premises, but the general principles may be applied and utilised for other types of developments generating greywater.



## 1.2 DEFINITIONS

**Absorption** – uptake of liquid into the soil.

**Aerobic Treatment Unit** – a self contained electrical wastewater (sewage) treatment system for treating sewage either wholly or partially by aerobic means.

**Alternating Trench** – a system that has two or more trenches and a diverter box that can alternate the flow of greywater allowing one of the trenches to be shut off at any time, allowing the unused trench to dry out, which rejuvenates the soil's ability to receive greywater.

**Blackwater** – is the wastewater generated from toilets and is contaminated with faeces and urine.

**BOD<sub>5</sub> (Biochemical Oxygen Demand)** – a measure of the dissolved oxygen required for the breakdown of organic material in the effluent; usually refers to a five day test which typically represents 70 – 80% of the total BOD in a sample; expressed in milligrams per litre (mg/L).

**Disinfection** – a process which reduces the number of micro-organisms but does not sterilise or remove all micro-organisms.

**Diversion Devices** – a hand activated switch that diverts filtered greywater by gravity or pump directly to a sub-soil irrigation trench. A diversion device incorporates an overflow device, filter and a hand activated valve, switch or tap which is fitted to the outlet of the waste pipe of the plumbing fixture such as a laundry tub.

**Diverter** – a device that allows the manual diversion of greywater to either the greywater system or the primary sewerage system.

**Greywater** – untreated household wastewater which has not come into contact with toilet waste (black water). It comes from the bath, shower, bathroom wash basin, kitchen sink, dishwasher, clothes washing machine and laundry trough.

**Greywater Reuse** – the application of greywater for a beneficial use. Reuse does not include disposal at a depth which would not be a beneficial use to plants and gardens.

**Greywater Systems** – consist of the greywater diversion, treatment, storage and distribution equipment that reuses greywater for garden irrigation.

**Overflow Device** – a device that allows greywater to automatically overflow into the primary sewerage system.

**Pathogens** – disease causing microbes eg viruses, bacteria, helminths and protozoa.



**Phosphorus Retention Index (PRI)** – a measure of the soils ability to bind phosphorous. The PRI is defined as the ratio of amount of Phosphorus (P) adsorbed to 5 grams of soil, expressed as mg P/kg of soil, and concentration in solution (mgP/L) after addition of 100 mL of a 10 mg/L P solution in 0.02 M KCl and equilibration for 18 hours. The practical scale of PRI is from 0 to about 1000 (above which results become meaningless). A PRI of 20 indicates that 5 mg P/L remains in solution after the initial addition of 10 mg P/L in 100 mL to 5 grams of soil.

**Primary Sewerage System** – is either the municipal sewerage system, septic tank system or aerobic treatment unit, which ever system is primarily responsible for removing the wastewater from the property or treating it on site.

**Primary Treatment Systems** – these systems utilise a sedimentation tank or other filtering devices to separate and remove settleable and floatable solids, oils/greases, lint, hair and other particles.

**Public Drinking Water Source Areas (PDWSAs)** – those areas declared under the *Metropolitan Water Supply, Sewerage and Drainage Act 1909*, and the *Country Areas Water Supply Act 1947* for the management and protection of water sources used for public drinking water supply. They include Underground Water Pollution Control Areas, Water Reserves and Catchment Areas. A three-tier priority classification system is used to manage PDWSAs, these are:

- **Priority 1 Source Protection Areas** are defined to ensure that there is no degradation of the water source. Priority 1 areas are managed in accordance with the principle of risk avoidance, so land development is generally not permitted.
- **Priority 2 Source Protection Areas** are defined to ensure that there is no increased risk of pollution to the water source. Priority 2 areas are managed in accordance with the principle of risk minimisation, so some development is allowed under specific guidelines.
- **Priority 3 Source Protection Areas** are defined to manage the risk of pollution to the water source. Priority 3 areas are declared over land where water supply sources need to co-exist with other land uses such as residential, commercial and light industrial developments.

**Relevant Sewerage Provider** – the body holding a licence from the Economic Regulatory Authority for the provision of sewerage services, which would be affected by the application of a sewerage requirement to a proposed subdivision or development.

**Reticulated Sewerage** – a network of sewers collecting wastewater, for off-site disposal from a subdivision or development.

**Secondary Treatment Systems** – these systems treat and disinfect greywater to 20mg/L BOD<sub>5</sub>, 30mg/L SS standard prior to irrigation via drip and/or surface irrigation methods.

**Sewage** – see Wastewater



**Sewer** – a collection drain which conveys sewage to the treatment plant.

**Sewerage** – the network of collection drains carrying domestic wastewater to the treatment plant.

**Sub-Soil Trench Irrigation** – this term is commonly used to denote utilisation of greywater by the trench method below ground level.

**Sub-Strata Drip Irrigation** – this term is commonly used to denote utilisation of greywater by trickle or micro-drip irrigation where the system is placed on the top of the ground surface and covered with a minimum of 100mm of approved material (eg bark, woodchips) placed over the irrigation pipework.

**Sub-Surface Drip Irrigation** – this term is commonly used to denote utilisation of greywater by trickle or micro-drip irrigation which is at a minimum depth of 150mm below ground level.

**Surface Spray Irrigation** – greywater applied to the ground from above the ground surface.

**SS (Suspended Solids)** – in wastewater analysis, solids retained after filtration through a glass fibre filter paper followed by washing and drying at 105°C, or by centrifuging, followed by washing and removal of the supernatant liquid; expressed in milligrams per litre (mg/L).

**Thermotolerant Coliforms** – (also known as faecal coliforms) a subset of coliforms found in the intestinal tract of humans and other warm blooded animals. Consists chiefly of *E.coli*. They are used as indicators of faecal pollution and effectiveness of disinfection processes and measured as a colony forming unit or cfu/100mL.

**Wastewater** – the used water arising from domestic activities consisting of all wastes, greywater and blackwater.



## 1.3 ABBREVIATIONS

The following abbreviations are used in this document:

<b>AS</b>	Australian Standards
<b>ATU</b>	Aerobic Treatment Unit
<b>BOD<sub>5</sub></b>	Biochemical Oxygen Demand - 5 days
<b>cfu</b>	colony forming unit
<b>DOE</b>	Department of Environment
<b>DOH</b>	Department of Health
<b>EDPH</b>	Executive Director, Public Health
<b>L</b>	Litre
<b>m</b>	metre
<b>mL</b>	millilitre
<b>mm</b>	millimetre
<b>PRI</b>	Phosphorus Retention Index
<b>SS</b>	Suspended Solids (includes NFR or Non Filterable Residue)

## 1.4 CHARACTERISTICS OF HOUSEHOLD GREYWATER

The characteristics of greywater produced by a household will vary according to the number, age, lifestyle, health status and water usage patterns of the occupants.

There are essentially three different greywater streams, they are:

- **Bathroom Greywater (bath, basin, and shower)** – contributes about 55% of the total greywater volume. Bathroom greywater can be contaminated with hair, soaps, shampoos, hair dyes, toothpaste, lint, nutrients, body fats, oils and cleaning products. It also has some faecal contamination (and the associated bacteria and viruses) through body washing.
- **Laundry Greywater** – contributes about 34% of the total greywater volume. Wastewater from the laundry varies in quality from wash water to rinse water to second rinse water. Laundry greywater can have faecal contamination with the associated bacteria and viruses, lint, oils, greases, chemicals, soaps, nutrients and other compounds.



- **Kitchen Greywater** – contributes about 11% of the total greywater volume. Kitchen greywater is heavily polluted with food particles, cooking oils, grease, detergents, and other cleaning products such as dishwashing powders. The detergents and cleaning products may be alkaline and contain chemicals that are harmful to soil structure, plants and groundwater. The solid food particles and fats can solidify and are not readily broken down by soil organisms which can result in blockages in the land irrigation system. It can also cause the soil to become water repellent. It is for these reasons that kitchen wastewater may not be well suited for reuse in all types of greywater systems.

**Note:** Kitchen greywater should **NOT** be reused via manual bucketing or diversion devices.

### 1.4.1 Household Water Usage Volumes

The **AVERAGE HOUSE (based on 3.3 persons per house)** uses 459 kilolitres of water per year or approximately **1259 litres each day**. This equates to approximately **117L of greywater per person per day**, of this 24 litres is used in the kitchen, 42 litres is used in the laundry and 51 litres is used in the bathroom. Approximately 707 litres each day is used outdoors for garden watering, pools and car washing etc.

Water usage will vary according to the water use practices of each household. The various percentages of household water use volumes are shown in Figure 1.

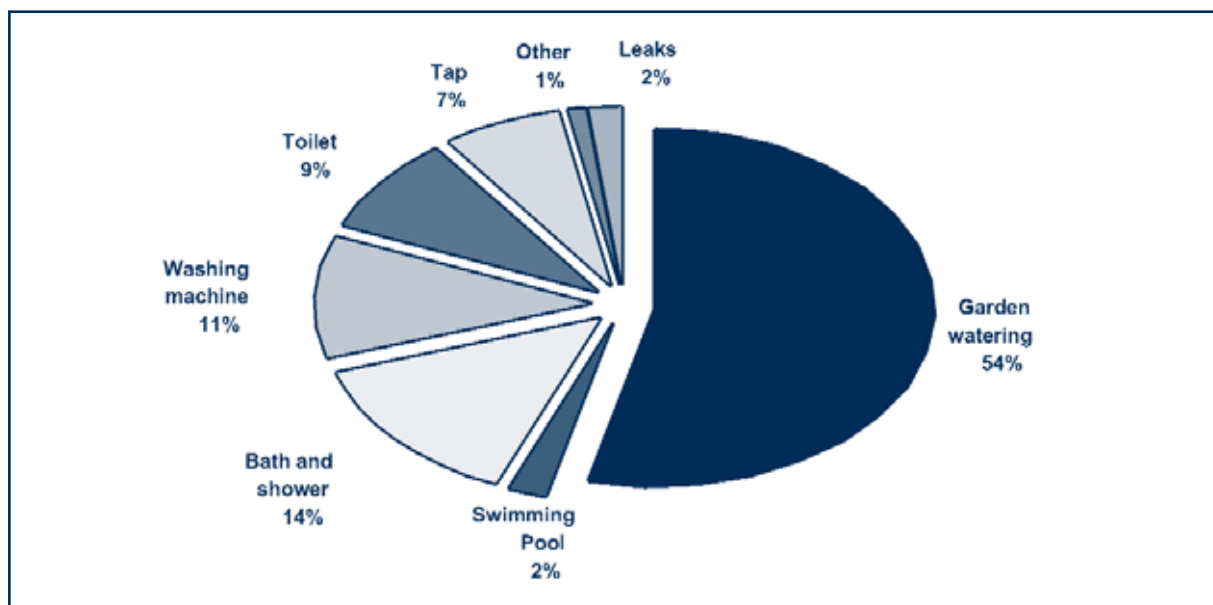

**Figure 1: Household Water Usage (Single Residential)**

**Source: Domestic Water Use Study in Perth, Western Australia 1998–2001 (Loh 2003)**



## 1.4.2 Composition of Household Greywater

Table 1 documents some examples of microbiological quality (i.e. the number of thermotolerant coliforms) of greywater from various sources in a residential dwelling.

Thermotolerant coliforms are also known as faecal coliforms (expressed as colony forming units (cfu) per 100mL) and are a type of micro-organism which typically grow in the intestine of warm blooded animals (including humans) and are shed in their millions per gram of faeces. A high faecal coliform count is undesirable and indicates a greater chance of human illness and infections developing through contact with the wastewater.

It is useful to bear in mind while reading the following table that typical levels of thermotolerant coliforms found in raw sewage are in the order of  $10^6$  to  $10^8$  cfu/100mL and from  $10^6$  to  $10^{10}$  cfu/100mL in septic tank effluent (i.e.  $10^6$  to  $10^8$  means 1,000,000 to 100,000,000).

**Table 1: Faecal Coliform Numbers in Greywater Prior to Storage**

SOURCE	FAECAL COLIFORMS(cfu)/100ML			
	Rose et. al. (1991)	Calif. DHS (1990)	Brandes (1978)	Kapisak et.al (1992)
Bathing/Shower	$6 \times 10^3$ cfu	$4 \times 10^5$ MPN	< 10 to $2 \times 10^8$	$6 \times 10^3$ cfu
Laundry Wash Water	126 cfu	$2 \times 10^3$ - $10^7$ MPN		
Laundry Rinse Water	25 cfu			
Kitchen			<10 to $4 \times 10^6$ $9 \times 10^5$	$2 \times 10^9$
Combined Greywater	6 to 80 cfu <sup>A</sup> $1.5 \times 10^3$ cfu <sup>B</sup> $1.8 \times 10^5$ to $8 \times 10^6$ cfu		$8.8 \times 10^{5CD}$ $13 \times 10^{6D}$	$1.73 \times 10^5$

A – families without children

B – families with children

C – other study quoted

D – kitchen and bath only

Source: Jepperson and Solley (1994)

cfu – colony forming units/100ml

MPN – most probable number

The chemical and physical quality of greywater compared with raw sewage (i.e. domestic wastewater) is shown in Table 2. The high variability of the greywater quality is due to factors such as source of water, water use efficiencies of appliances and fixtures, individual habits, products used (e.g. soaps, shampoos, detergents etc.) and other site specific characteristics. It should be noted that the following comparison of greywater and raw sewage highlights that greywater is still a relatively contaminated wastewater stream, and therefore should be managed carefully.



**Table 2: Typical Composition of Greywater compared with Raw Sewage**

Parameter	Unit	Greywater <sup>a</sup>		Raw Sewage
		Range	Mean	
Suspended Solids	mg/L	45 – 330	115	100 – 500
Turbidity	NTU	22 – >200	100	NA
BOD <sub>5</sub>	mg/L	90 – 290	160	100 – 500
Nitrite	mg/L	<0.1 – 0.8	0.3	1 – 10
Ammonia	mg/L	<1.0 – 25.4	5.3	10 – 30
Total Kjeldahl Nitrogen	mg/L	2.1 – 31.5	12	20 – 80
Total Phosphorous	mg/L	0.6 – 27.3	8	5 – 30
Sulphate	mg/L	7.9 – 110	35	25 – 100
pH		6.6 – 8.7	7.5	6.5 – 8.5
Conductivity	mS/cm	325 – 1140	600	300 – 800
Hardness (Ca & Mg)	mg/L	15 – 55	45	200 – 700
Sodium	mg/L	29 – 230	70	70 – 300

<sup>a</sup> Based on Jeppesen and Solley (1994)

NA – Not Applicable

## 1.5 HEALTH AND SAFETY REQUIREMENTS

The health of a household is usually reflected in the wastewater produced. However, a household enjoying good health will still excrete pathogenic micro-organisms which are a normal part of the gut. All forms of greywater are capable of transmitting disease.

Pathogens from greywater may spread by direct contact (i.e. touching greywater or inhaling infectious water droplets) or indirectly by consumption of food or water contaminated with greywater. The characteristics of household greywater are outlined in Section 1.4.

To minimise the risk to public health and prevent a nuisance from greywater reuse, the following requirements apply:

- 1.5.1 Greywater systems (this does not include bucketing) must dispose of greywater below the ground surface unless treated and disinfected to an appropriate standard (see Part 3, Table 3).
- 1.5.2 The system must be designed and operated to exclude human and animal contact with the greywater except as required to maintain the system.
- 1.5.3 No cross connection with the potable water supply is allowed.



- 1.5.4 Greywater must not be allowed to enter any stormwater drainage system.
- 1.5.5 Greywater shall not be used in a manner that will result in direct contact with vegetables or other edible plants. It may be used to irrigate above-ground food plants such as fruit trees and leaf vegetables where the fruit or edible vegetable part does not make direct contact with the greywater.
- 1.5.6 No opportunity for mosquito breeding is to exist in any part of a greywater system. A major concern with using greywater is the potential health risks associated with ponding of greywater on the ground surface which can provide ideal habitats for mosquitos to breed.
- 1.5.7 If irrigated via *sub-strata drippers* or *above ground sprays* (note: this does not include subsurface trenches or manual bucketing) it is desirable in each irrigation area to have signage effectively cautioning those entering the area that greywater is being used for irrigation. The sign should be on a white background with red lettering at least 20mm high. The sign should state: "Warning Greywater Irrigation Area".
- 1.5.8 All irrigation pipework must be colour coded in the international colour for wastewater identification i.e. a purple colour. This allows identification and differentiation between a bore or scheme water reticulation system and the greywater pipelines.

## 1.6 ENVIRONMENTAL REQUIREMENTS

The Government has committed significant funds to provide infill sewerage to many unsewered urban areas in Western Australia. Reticulated sewerage is considered the most reliable, efficiently managed and environmentally acceptable means of wastewater disposal. Wastewater treatment plants are designed, controlled and monitored to ensure that the quality of treated wastewater is satisfactory for release back to the environment, with minimal impact and the greatest regard for public health.

For these reasons, including environmental concerns about nutrient impacts, namely phosphorus and nitrogen from septic tank systems, reticulated sewerage is used extensively throughout Western Australia. It would therefore be irresponsible to divert greywater from the sewer for reuse onsite in locations where nutrients from greywater could negatively impact on nearby environmentally sensitive water bodies without suitable protective measures being implemented.

To minimise negative impacts on the environment from greywater reuse, the following requirements apply:



1.6.1 Greywater must be contained within the confines of the premises on which it is generated and not be permitted to run off onto neighbouring properties. Greywater must also not be allowed to run onto driveways or other hard surfaces where it can run into the street and into stormwater drains and eventually into the river systems.

1.6.2 Only products with no or very low phosphorus content should be used. Phosphorus content can range from a low content of 0.05% up to 10% in various detergents.

Many native plants (not all) are sensitive to additional phosphorus. Plants of the Proteaceae family (such as grevillea, hakea and banksia) are susceptible to excess phosphates. These plants are not ideally suited for irrigation with greywater.

Low or no phosphorus products will mean less phosphorus can possibly reach waterways via subsoil flow, runoff or stormwater, which can create serious water quality problems. (See [www.lanfaxlabs.com.au](http://www.lanfaxlabs.com.au) for the phosphorus levels of common laundry products.)

The symbol **NP** is used to identify products which have no added phosphorus, although levels below 0.5% may be present. The symbol P denotes “the product complies with agreed industry standards on phosphorus, which impose a maximum content of 7.8 grams per wash”. A phosphorus content of 7.8 grams per wash is equivalent to a concentration in the average full wash load (i.e. the recommended dose of product with the full water load is 160 litres of wash, rinse, deep rinse and spin cycle) of 50mg L<sup>-1</sup> (Patterson, 1999).

1.6.3 Greywater tends to be slightly alkaline, with a typical pH range of between 6.5 and 10.5, and the extensive use of greywater for irrigation could cause the soil to become progressively more alkaline.

A washing detergent’s ability to remove stains is linked to the pH. Soil and greases are more easily removed at a high pH. Shade loving and acid loving plants do not like the alkalinity of greywater. These include azaleas, camellias, gardenias, begonias and ferns.

1.6.4 Washing powders that contain sodium salts as bulking agents should be used sparingly. High levels of sodium can produce saline (i.e. salty) greywater. Sodium is detrimental to plants can, damage soil structure, reducing the air space, giving it a greasy texture and poor drainage capability. (See [www.lanfaxlabs.com.au](http://www.lanfaxlabs.com.au) for the sodium levels of common laundry products).

1.6.5 Liquid detergents (instead of powders) or products which use potassium salts should be used as they produce better quality, less saline greywater.



- 1.6.6 Detergents and powder cleansers contain boron and should be used sparingly, as boron can be toxic to plants in high concentrations and can also be toxic to animals.

The USA Environmental Protection Agency (1992) recommends the maximum boron concentration be 0.75g/L for long term use on sensitive plants.

- 1.6.7 Try to avoid the use of:
- bleaches or softeners,
  - detergents that advertise whitening, softening and enzymatic powers,
  - detergents with ingredients which include: boron, borax, chlorine, bleach, sodium perborate and sodium tryochlorite (salts), sodium tripolyphosphates (STPP), phosphorus, phosphates, polyphosphates, phosphate builders, acids etc, and
  - products used to clean drains.

- 1.6.8 The following materials should not enter a greywater system:
- paints, automotive oils and greases etc, and
  - any matter designated as trade waste or industrial liquid waste.

- 1.6.9 In soils where the phosphorous retention index (PRI) of the soil is less than 5, the greywater systems should be installed more than 100 metres away from any wetland, streamflow or other water sensitive ecosystems. Information about local water features can be obtained from the DOE.

Greywater systems within 100 metres of a Priority 1 Drinking Water Source Protection Area must be approved by the Department of Environment.

If within a Priority 1 Drinking Water Source Protection Area, the PRI of the soil will need to be assessed by a soil scientist. Soil tested must be collected from the soil in which the greywater is to be irrigated. The testing procedure must be conducted by a NATA registered laboratory.

- 1.6.10 System flow rates on coarse sandy soil/gravel should be carefully designed to avoid greywater directly entering surface water bodies.

- 1.6.11 Compost mulches should be used in greywater irrigation areas to facilitate decomposition of greywater waste residues.





## PART 2

# HOMEOWNER'S GUIDE TO REUSING GREYWATER

## PART 2

2.1	REDUCING WATER USAGE	16
2.2	WHAT CAN I DO TO REUSE MY GREYWATER?	16
2.3	GREYWATER SYSTEMS APPROVED FOR USE	18
2.4	INSTANCES WHERE GREYWATER REUSE IS NOT PERMITTED	19
2.5	PROCEDURE FOR OBTAINING A PERMIT TO INSTALL A GREYWATER SYSTEM	19
2.6	SYSTEM MAINTENANCE	21



## PART 2. HOMEOWNER'S GUIDE TO REUSING GREYWATER

### 2.1 REDUCING WATER USAGE

Domestic reuse of greywater will help the environment by reducing demand on higher quality bore and scheme waters. However, greywater reuse is only part of the approach we need to adopt to protect our water resources. To conserve ground and surface water resources, even before considering greywater reuse, it is essential that water conservation is practised. Greywater generation should be minimised for three important reasons:

- to conserve drinking water as a precious natural resource;
- to ensure that greywater does not overload the installed greywater land application system; and
- to minimise land requirements for a greywater system.

Various water-saving devices can be used to conserve water, including dual flush toilet cisterns, low-flow taps and reduced flow shower heads, dishwashers and front loading washing machines. Water may also be conserved using a range of practices such as shorter showers, turning the tap off when cleaning teeth, ensuring that taps do not drip, and using dishwashers and clothes washers only when the machine is full. As 47% of household water usage is for garden watering, a water wise garden can greatly reduce water use. For more information on ways to save water in the home contact the Water Corporation (see contact details on page 39).

### 2.2 WHAT CAN I DO TO REUSE MY GREYWATER?

Greywater can either be reused via

Bucketing

OR

Installing an **APPROVED** greywater system.

#### 2.2.1 How can I reuse greywater via a bucket?

Manually irrigating greywater using a bucket (e.g. bucketing laundry wastewater) to absorptive soils is acceptable provided that the health and safety conditions are complied with. See Appendix 1 for the “Guidelines for bucketing greywater”.



## 2.2.2 Installing an approved greywater system

All greywater systems must be approved by the Department of Health, Western Australia. This ensures that all systems available to the general public comply with the relevant Department of Health and Water Corporation regulations and are safe, compatible with household plumbing, and will provide effective long term operation.

Greywater systems can range from those that provide primary treatment which coarsely filter or settle out oils, greases and solids from the greywater before irrigation via small trench systems, to more expensive secondary treatment systems which treat and disinfect the greywater to a high standard before irrigating it via microdrip or spray systems.

**Primary treatment** systems are usually more economically attractive as they require only minimal maintenance and generally do not require electricity and chemicals for their operation. However, these systems are limited to below ground greywater irrigation.

**Secondary treatment** systems are more expensive than primary treatment systems due to the initial establishment costs associated with the more complex treatment process and the ongoing maintenance costs. However, the higher level of treatment of the greywater allows for a much more conventional surface irrigation system such as above ground sprays.

The choice of an appropriate greywater system for each household will depend on a number of factors. Issues which should be considered include:

- do you live in a sewerred area?
- do you live in a non sewerred location?
- will the system be installed in a new home?
- will the system be installed in an existing home?
- is a disused wastewater system being converted to a greywater system because the property has been connected to sewer?

**In sewerred areas** greywater systems must have an overflow device so that greywater can be diverted to sewer in winter months, when the garden does not require additional watering. A backflow prevention device is also fitted to protect property owners from any sewerage overflows in the event of a fault in the sewerage system.

**In non-sewerred areas** there is no need for a backflow prevention device, although a diverter should still be fitted to allow the greywater to be directed into the existing septic tank system in winter months, when the garden does not require additional watering.

**In new homes** there are more options when choosing a greywater system as garden beds can be planned, appropriate plants chosen and areas for the location of the treatment system can be set aside before construction of the home commences.



**In existing homes** consideration must be given to fitting a system within the property boundaries, and identifying areas of garden which will most benefit from greywater reuse. House plumbing may also require modification to allow for the safe diversion of greywater from the existing household wastewater stream.

**If a disused onsite wastewater system is being converted** to a greywater system because the property has been connected to reticulated sewer, consideration will need to be given to any necessary modifications to the existing treatment process and the installation of an approved sewer overflow and backflow prevention device. The existing disposal field (e.g. leachdrains or soakwells) may also need to be adapted for effective greywater reuse rather than disposal.

## 2.3 GREYWATER SYSTEMS APPROVED FOR USE

The following greywater systems are approved by the Department of Health for use in Western Australia:

- Any **'Executive Director, Public Health approved system'** (approved on an individual basis);
- Systems which utilise a sedimentation tank and sub soil trench irrigation system constructed as prescribed in Part 3, Section 3.1.2 and Appendix 3 and sized as detailed in Part 3, Sections 3.4.2 and 3.4.3;
- Systems which convert disused septic tank systems to greywater systems as detailed in Appendix 3; and
- Systems which convert Aerobic Treatment Units (ATU) to greywater systems as detailed in Appendix 4.

It is anticipated that with the release of this Code, new innovative greywater system designs may be approved by the Department of Health.

A current list of all greywater systems approved by the Department of Health for use in Western Australia, and advice on choosing the most appropriate system for your household, can be obtained from your Local Government office or the Wastewater Management Branch of the Department of Health on (08) 9388 4999.



## 2.4 INSTANCES WHERE GREYWATER REUSE IS NOT PERMITTED

It may not be appropriate for greywater systems to be installed in all circumstances. Approval will not be granted for the installation of greywater systems under the following circumstances:

- The greywater system (or system design) is not one approved by the Executive Director, Public Health.
- The property is connected to a municipal effluent reuse system and the Sewerage Service Provider will not approve the diversion of greywater from the reuse scheme.
- The property is in an environmentally sensitive area (see Part 1, Section 1.6.9).
- Inappropriate site conditions exist (e.g. unsuitable soils and/or elevated ground water levels).
- Insufficient property area is available to achieve the necessary setbacks and area required for irrigation.

## 2.5 PROCEDURE FOR OBTAINING A PERMIT TO INSTALL A GREYWATER SYSTEM

Only greywater systems that comply with Part 3, Section 3.1 of this Code and have been approved by the Executive Director, Public Health for use in Western Australia may be installed.

Installation of an approved greywater system or conversion of an existing septic tank system or aerobic treatment unit to a greywater system must be approved by the Local Government for the area in which the system is to be installed, and will require a formal application to be made and payment of all relevant fees.

If a greywater system is to be installed in a sewerred area, modifications to the plumbing as well as the installation of an approved sewer overflow device and diverter will be required.

**All greywater system applications for single dwellings up to (and including) 10 persons are to be made to and approved by the Local Government.**

All greywater systems above 10 persons are to be submitted to the Executive Director, Public Health for approval as is the procedure for septic tank applications greater than 540L/day under Section 4A of the *Health (Treatment of Sewage and Disposal of Effluent and Liquid Waste) Regulations 1974*.



### 2.5.1 Application

An *Application to Construct or Install an Apparatus for the Treatment of Sewage* form can be obtained from the Local Government. The applicant must complete the relevant sections, including:

- Greywater source to be reused (e.g. laundry or bathroom etc).
- Number of bedrooms in the house.
- Brand name and details of the proposed system.
- A detailed site layout plan (in duplicate or triplicate as the case requires) drawn to a scale of 1 in 500 showing:
  - block dimensions;
  - natural ground contours, wells, bores, dams, watercourses and depth to groundwater;
  - existing and proposed buildings, other structures and paved areas;
  - details and location of any diversion trenches to collect surface or migrating subsurface water;
  - details and location of roof water disposal;
  - setback distances from boundaries, buildings, surface irrigation area and other structures; and
  - details of the sewer overflow pipework where this is intended.
- Details of the treatment and irrigation systems including:
  - proposed location of greywater system and reuse area including the position of irrigation lines/trenches;
  - method of construction of surface irrigation area bed, including the materials to be used; and
  - where a split irrigation system is used; details of mechanisms to ensure an even discharge to each area and to prevent overloading of individual areas.
- The application, inspection and Local Government report fees as currently prescribed.

Failure to supply all requested information will delay consideration of the application.

Greywater systems within 100 metres of a Priority 1 Drinking Water Source Protection Area must be approved by the DOE.

As part of the approval procedure, the Local Government must seek approval from the Water Corporation, or other responsible Sewerage Service Provider, for the diversion of greywater from the sewer system, in regard to possible negative impacts on the sewerage system or wastewater reuse scheme. This approval need only be requested once for each locality. Local governments shall only issue approval for the use of greywater systems in seweraged locations where the Sewerage Service Provider has indicated they have no objections.



Throughout Western Australia, especially in rural areas, household wastewater collected by some sewerage systems is treated and then reused to irrigate town sporting ovals and parks. Therefore, in some instances approval may not be granted by the Sewerage Service Provider for greywater reuse as the wastewater is required for other purposes.

All plumbing work in seweraged areas must be undertaken by a plumber licensed under the *Water Services Coordination (Plumbers Licensing) Regulations 2000* and must comply with the *AS/NZS 3500 – National Plumbing and Drainage Code*. The plumber must obtain approval from the Sewerage Service Provider for any required connection or modification to the plumbing works connected to the sewer system.

## **2.5.2 Installing a System**

It is an offence to commence construction of a greywater system without an approval. Once the Local Government, or the EDPH in the case of systems >540L/day, issues an approval to construct or install a greywater system, the system may be constructed, but not used.

Before a greywater system may be used, the Local Government must inspect the system (before excavations are refilled) to ensure that it is installed correctly. If satisfactory, the Local Government will issue an approval for the system to be used. It is an offence to commence using the system prior to receiving the Local Government's approval.

## **2.6 SYSTEM MAINTENANCE**

Most greywater systems require an individual's efforts to maintain the system. Once a greywater system is installed it becomes the householder's responsibility to ensure it is managed in accordance with the manufacturer's instructions and is maintained in good working order. Any defect must be rectified as soon as it becomes apparent. Should the system cause a nuisance that is dangerous to health or it is offensive, the owner's may expose themselves to legal liabilities.

Some greywater systems require regular maintenance e.g. weekly cleaning or replacement of filters, periodic desludging, manually diverting greywater back to the primary sewerage system (e.g. sewer, septic tank, ATU) in winter and flushing of irrigation lines.

Operation and maintenance of systems will be the cost of the householder. Costs include the initial construction expenses, power to operate pumps, replacement of filters, cleaning of irrigation lines and desludging of sedimentation tanks.



Some greywater systems (e.g. aerobic treatment units) will require homeowners to enter into a maintenance contract with the installer or other authorised service agent.

Homeowners should manually divert the greywater stream back into the sewer or existing septic system in times of rainfall e.g. winter/spring. This is essential to avoid over-watering of soils during the wet season (e.g. winter/spring rain period) and addition of nutrients in excess of plant uptake requirements. Inappropriate application of soluble nutrients during periods of reduced plant growth and transpiration will result in leaching losses to shallow ground water that can cause eutrophication of natural water features on the Swan Coastal Plain.

Homeowners may be required to carry out other work after system start-up including but not limited to the following:

- regular maintenance of systems with filtering devices.
- systems with two reuse areas require regular diversion.
- sedimentation tanks require desludging approximately every 5 years.
- test the soils for pH and sodicity on a regular basis. The addition of gypsum may be needed to help eliminate any build up of sodium and magnesium. Also, occasionally test for nutrient levels to make sure there is no overuse of fertiliser.
- tanks should be regularly inspected for the presence of mosquito breeding, which if found should be eliminated and the point of entry sealed or screened.
- insect screens on vents and inspection ports should be regularly inspected and cleaned or replaced if blocked or damaged.
- ensure excess watering does not occur. Over watering can lead to waterlogging and plant death.

When conducting maintenance (e.g. cleaning filters etc) involving greywater the householder should ensure they:

- avoid direct contact with the skin through the use of rubber gloves and protective clothing;
- ensure that cuts, sores, open wounds etc are adequately protected (by a waterproof covering) from any contact with greywater;
- ensure that exposed body areas that come into contact with greywater are effectively washed;
- do not make contact with the mouth or face either directly (e.g. fingers, hands) or indirectly (e.g. smoking) until after washing hands; and
- do not eat food until hands have been thoroughly washed.



## **PART 3**

# **INFORMATION FOR GREYWATER SYSTEM DESIGNERS AND LOCAL GOVERNMENT**

### **PART 3**

3.1	DESIGN AND PERFORMANCE REQUIREMENTS	24
3.2	GREYWATER SYSTEM OPTIONS	27
3.3	GREYWATER IRRIGATION OPTIONS	29
3.4	DESIGNING A GREYWATER SYSTEM	31
3.5	SITING A GREYWATER IRRIGATION SYSTEM	36
3.6	MATERIALS FOR IRRIGATION AREAS	38



## PART 3. INFORMATION FOR GREYwater SYSTEM DESIGNERS AND LOCAL GOVERNMENT

### 3.1 DESIGN AND PERFORMANCE REQUIREMENTS

All greywater systems are an “Apparatus for the Treatment of Sewage” as defined under Section 3(1) of the Health Act 1911, and as such their design, manufacture and use must be approved by the Executive Director, Public Health.

A greywater system is to be designed, constructed, operated and maintained in accordance with the following:

3.1.1 Primary greywater systems are to incorporate below ground irrigation methods (i.e. greywater must not be disposed of on top of the ground surface). Secondary treated greywater **if disinfected** can be irrigated above the ground surface (see Part 3, Table 3).

3.1.2 Primary treatment greywater systems must incorporate a filtering system (see 3.1.11) or a sedimentation tank to remove fats, greases and solids.

Greywater systems that treat **all** greywater streams from domestic dwellings (i.e. kitchen, bathroom and laundry) must have a sedimentation tank that has a minimum volume of 1820L or be treated via an aerobic treatment unit.

Greywater systems that treat bathroom and/or laundry greywater only, via a sedimentation tank, must be designed to provide at least 24 hour combined retention for the daily flow of greywater (i.e. double the daily flow).

3.1.3 Variations to the above design requirements will be considered for greywater systems proposed by manufacturers. These systems will need to demonstrate that effective long term operation of the system can be expected. Depending on the nature of the system, demonstration of this may require the system be subjected to a performance trial.

3.1.4 **Manufacturers of mechanical greywater systems must adequately demonstrate to the satisfaction of the Department of Health that the system can be operated effectively in the long term without blockages between servicing.**



Depending on the nature of the product a performance trial may be required prior to an approval. Such systems are to be provided with a manufacturer's warranty and to prescribe which greywater streams they are designed for and detail all owner maintenance requirements. The Department of Health may require that certain designs only be permitted if maintained by an authorised maintenance person (e.g. the manufacturer) and require formal maintenance contract arrangements to be put into place.

- 3.1.5 Irrigation lines (e.g. dripper emitters, trickle systems etc) must be suitable for long term operation, having regard for the likely greywater quality from the treatment system.
- 3.1.6 Irrigation pipework must be colour coded in the international colour for wastewater identification i.e. a purple colour. This allows identification and differentiation between a bore or scheme water reticulation system and the greywater pipelines.
- 3.1.7 Greywater systems in sewered locations must have an automatic overflow and a manual diverter to the sewer fitted and installed in accordance with the manufacturer's instructions.
- 3.1.8 Greywater systems in unsewered areas *should* have an automatic overflow and a manual diverter fitted to allow the greywater to be directed into the existing septic system or ATU in winter months.
- 3.1.9 Manufacturers of sewer diversion/overflow devices must have their device approved by the Water Corporation as required by the *AS/NZS 3500 – National Plumbing and Drainage Code*. Please contact the Plumbing Testing Laboratory phone (08) 9380 7499 to discuss how to apply for approval.

Automatic overflow connections from a greywater system back to the primary sewerage system must be fitted with an approved antibackflow/reflux valve, except where the invert level of the overflow connection point on the greywater system is set at minimum of 150mm above the overflow relief gully.

- 3.1.10 The overflow device shall be designed in a manner that should the irrigation or filtering system cease to operate satisfactorily or the diversion is turned off the greywater will automatically overflow into the primary sewerage system.
- 3.1.11 Systems that physically capture/filter solids from specific greywater streams prior to irrigation and require the owners to regularly clean out filters etc, will only be permitted in sewered areas when their design incorporates an automatic overflow which occurs when the filter becomes clogged or the pump fails, and a manual diverter is installed prior to the system. Such systems are not permitted in unsewered locations unless they are fitted with an overflow or diverter to an onsite wastewater system designed to receive all wastewater.



- 3.1.12 Greywater diversion valves must be constructed in accordance with ATS 5200.460-2004 – Australian Technical Specification: Technical Specification for plumbing and drainage products – Part 460: Greywater diversion valve assembly.
- 3.1.13 Systems should be designed to ensure the easy disconnection of the irrigation system over winter/spring. This is essential to avoid over-watering of soils during the wet season (e.g. winter/spring rain period) and addition of nutrients in excess of plant uptake requirements. Inappropriate application of soluble nutrients during periods of reduced plant growth and transpiration will result in leaching losses to shallow ground water that can cause eutrophication of natural water features.
- 3.1.14 Greywater connections must be designed and installed to prevent sewer gases from entering the property. All plumbing work must be carried out by a plumber licensed under the Water Services Coordination (Plumbers Licensing) Regulations 2000 and must comply with the *AS/NZS 3500 – National Plumbing and Drainage Code*.
- 3.1.15 All treatment tanks and pump pits must comply with the structural and access requirements of *AS 1546.1 – “Onsite Domestic Wastewater Management: Septic Tanks”*.
- 3.1.16 Systems incorporating an irrigation pump must have a minimum pump pit capacity of 250L if they are fitted with a sewer overflow, or 250L plus one day’s reserve if on unsewered properties without an overflow to the combined septic system.
- 3.1.17 Systems incorporating an irrigation pump must be fitted with a high water level warning device, to warn of pump failure or system blockage. For systems with an overflow device this should trigger prior to the overflow occurring, and for systems without an overflow device at the 250L level.
- 3.1.18 A person with suitable qualifications and experience must design sub-soil pump pressurised trench irrigation systems. The system must have manifold lines not less than 40mm in diameter and laterals of not less than 25mm in diameter with not less than 3mm diameter holes spaced to give uniform distribution. It may be appropriate to engage a Certified Irrigation Designer to design the irrigation system to ensure it is designed correctly.
- 3.1.19 Systems must have sufficient irrigation area to ensure long term performance, taking soil types and likely greywater volumes into consideration.
- 3.1.20 Systems must be designed to avoid above ground pooling of greywater after its application to the soil.
- 3.1.21 Systems must be designed to avoid the likelihood of blockage or leakage in any part of the system.



- 3.1.22 Systems must have simply operated maintenance access points, with security against unauthorised access.
- 3.1.23 Systems must be ventilated to avoid accumulation of foul air or its entry to buildings or otherwise causing a nuisance. Vents shall be constructed as per *AS 3500.2.2 National Plumbing and Drainage Code*. Vent cowls shall be suitably screened to prevent entry by mosquitoes, flies and vermin.
- 3.1.24 Greywater has a high level of suspended solids, oils, grease etc which will clog irrigation lines. Therefore, is it essential that if drip or spray irrigation is intended, the greywater is filtered to a minimum of 140 mesh (115 micron) with a capacity of 100 litres per minute.
- 3.1.25 Greywater must undergo treatment to remove material that may clog pumps, block pipes and drippers or clog the soil.
- 3.1.26 Reuse of greywater via sub-strata and sub-surface micro-drip irrigation must comply with the requirements of the Department of Health, Western Australia (2001) *“Code of Practice for the Design, Manufacture, Installation and Operation of Aerobic Treatment Units (ATUs) Serving Single Dwellings – Dripper Irrigation Disposal Criteria”*.
- 3.1.27 An air release/vacuum relief valve at high points in a subsurface irrigation system is recommended.
- 3.1.28 It is preferable that only bathroom then laundry greywater be reused. Some greywater (i.e. from the kitchen) should be used to help flush sewer pipes to prevent blockages. Kitchen greywater is heavily polluted and may not be suited to most types of reuse (see Section 1.4).
- 3.1.29 Systems must be designed in accordance with the requirements of Table 3.

## **3.2 GREYWATER SYSTEM OPTIONS**

Greywater systems can be separated into four general categories as outlined below.

### **3.2.1 Manual bucketing of greywater**

Manually irrigating greywater using a bucket (eg. bucketing laundry greywater) to absorptive soils is acceptable provided that relevant health and safety conditions are complied with. These are detailed in Appendix 1.



### **3.2.2 Primary Treatment Systems**

Primary treatment methods either use a sedimentation tank or a filtering diversion device to coarsely screen out oils/greases and solids prior to irrigation via a sub-soil trench irrigation system. The basic requirements and examples are given in Appendix 3.

### **3.2.3 Secondary Treatment Systems**

Secondary treatment systems further treat the greywater to remove more of the oils/greases and solids than in primary treatment. This allows secondary treated greywater to be irrigated via micro-drip or surface irrigation methods (where disinfected), without the pipes becoming quickly clogged. The basic requirements and an example of a system are given in Appendix 4.

### **3.2.4 Other Treatment Systems**

Other examples of greywater systems that do not incorporate typical primary or secondary treatment tank systems are considered in a number of worldwide greywater publications. Examples might include systems that physically capture/filter out solids from specific greywater streams prior to irrigation and will require ongoing householder maintenance to regularly clean filters. It is likely that with the introduction of this Code, interest in the use of such products will occur. It is also anticipated that applications will follow from manufacturers seeking approval to allow the marketing and use of these systems in Western Australia (see Section 3.1).

For examples of other systems see the “Model Guidelines for Domestic Greywater Reuse for Australia” by the Urban Water Research Association of Australia Research Report 107, 1996.

Before the use or sale of greywater systems can be permitted in Western Australia they must have the approval of the Executive Director, Public Health. Before approval will be granted the Executive Director, Public Health will need to be satisfied that the use of the system and its design are acceptable for long term use.

Proponents, designers and inventors of greywater systems are encouraged to develop and make application for approval, but such approval will require that the suitability of the systems be demonstrated. This may necessitate a performance trial at the proponent's expense. Likewise, permission to trial systems will require that proponents satisfy the Executive Director, Public Health that the basic design concept appears sound.

Please contact the Wastewater Management Branch of the Department of Health on (08) 9388 4999 for further information about approvals for trialing and system design approval.



### 3.3 GREYWATER IRRIGATION OPTIONS

The appropriate greywater irrigation method is dependent on the treatment level.

**Table 3: Greywater Irrigation Options according to Treatment**

Treatment	Greywater Reuse Application
Untreated greywater	Bucketing
Primary treated greywater (i.e. treatment by either a sedimentation tank and/or a diversion device)	Sub-soil trench or Sub-surface drip irrigation* (*dependant on type of filter system)
Secondary treated to a 20 mg/L BOD <sub>5</sub> , 30 mg/L SS and possible disinfection to achieve <10 cfu thermotolerant coliforms/100mL	Surface spray irrigation, Sub-strata drip irrigation, Sub-surface drip irrigation, or Sub-soil trench

- Irrigation methods must be constructed in accordance with the relevant requirements of the *Health (Treatment of Sewage and Disposal of Effluent and Liquid Waste) Regulations 1974* and/or the AS 1547:2000 – “*Onsite Domestic Wastewater Management*”.
- Irrigation via spray or drip irrigation must be designed in accordance with the Department of Health, Western Australia (2001) “*Code of Practice for the Design, Manufacture, Installation and Operation of Aerobic Treatment Units (ATUs) Serving Single Dwellings – Dripper Irrigation Disposal Criteria*”.
- Irrigation of greywater below ground means water is not wasted through wind dispersal, evaporation and run off and it also reduces the scope for human contact and subsequent risk to public health.
- In sandy soils, soil conditioners should be added to improve the soil structure and help hold the greywater close to the root zone.
- Plants that are deep rooted should be selected, as some shallow rooted plants may not be able to reach enough water to sustain growth. Please contact your local garden centre for advice.

There are essentially 5 methods of greywater irrigation. These are:

- 1) **Manual Surface Irrigation** – the only permitted method for this is via manual bucketing as detailed in Appendix 1.



- 2) **Sub-Soil Trench Irrigation** – is irrigation by a below ground trench, where the base of the trench should not exceed a depth of 400mm below the surface. See Appendix 5. An example of a sub-soil trench is given below.

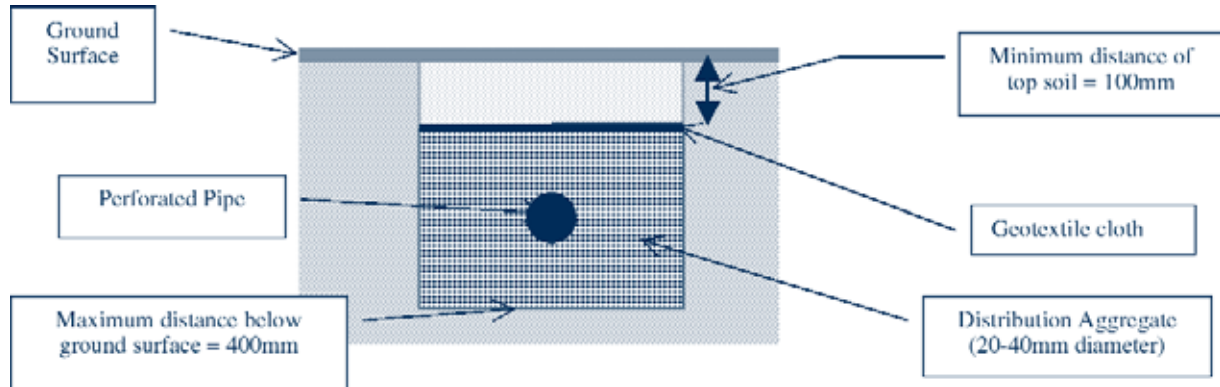

- 3) **Sub-Surface Drip Irrigation** – is irrigation by drip irrigation at a minimum depth of 100mm below ground level. To ensure long life for such a system the greywater must be treated to ensure the drip irrigation systems do not become blocked. An example of sub-surface drip irrigation is given below.

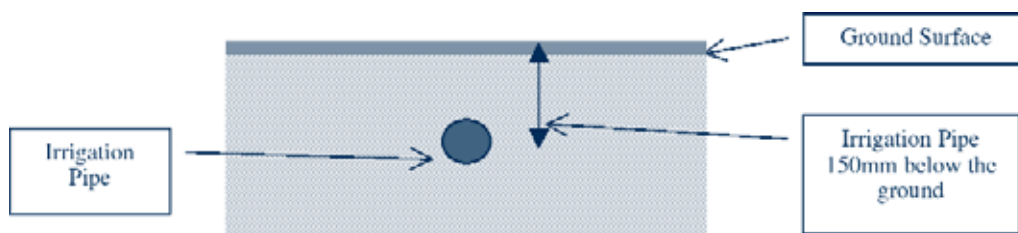

- 4) **Sub-Strata Drip Irrigation** – is irrigation by drip irrigation where the drip irrigation lines are placed on the top of the ground surface and covered with a minimum of 100mm of bark or woodchips. To ensure long life for such a system, the greywater must be treated to ensure the drip irrigation systems do not become blocked. An example of sub-strata drip irrigation is given below.

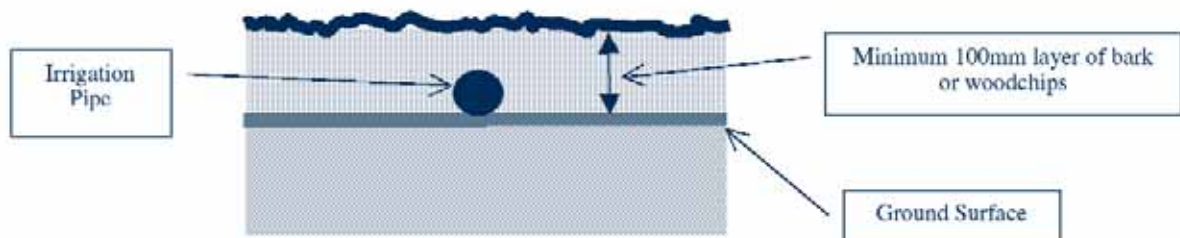

- 5) **Surface Spray Irrigation** – greywater is applied to the ground surface from above ground level with coarse droplets. This is only permitted where greywater has been treated and disinfected in accordance with Part 3, Table 3 prior to irrigation.



## 3.4 DESIGNING A GREYWATER SYSTEM

### 3.4.1 General

This Code is required to design a new greywater system. It may be appropriate for persons contemplating a greywater system to consult a wastewater system designer or other suitably qualified person to consider the options available.

To design a greywater system an estimation of greywater generation is needed and the site should be evaluated for the irrigation system.

### 3.4.2 Calculating Greywater Volumes

To estimate the volume of greywater generated in a household follow the steps below:

First calculate the number of occupants of a home as follows:

- 2 persons for first bedroom
- 1 person per additional bedroom

Next calculate each person's daily greywater flow allocation as

**117 litres per person per day \***

\* This figure is based on

**24L for kitchen,  
42L for laundry and  
51L for bathroom**

Greywater flow is based upon the number of bedrooms rather than the actual number of people who currently occupy a dwelling, because the number of bedrooms will remain constant, while the number of people may vary over time.



**Table 4: Daily Domestic Greywater Volumes**

Numbers of Bedrooms	Domestic Greywater Volumes (litres per day)			
	Greywater Source			Total Greywater Flow
	Kitchen*	Laundry	Bathroom	
2 or less	72	126	153	351
3	96	168	204	468
4	120	210	255	585
5 or more	144	252	306	702

(Note: \* A 1800L sedimentation tank is required for Greywater systems that include kitchen greywater unless otherwise approved by the Executive Director, Public Health)

### 3.4.3 Sizing Greywater Tanks

Greywater systems that treat all greywater streams (i.e. kitchen, bathroom and laundry) must have a sedimentation tank that has a minimum volume of 1820L, unless otherwise approved by the EDPH.

Greywater systems that only treat bathroom and/or laundry greywater via a sedimentation tank must be designed to provide at least 24 hour combined retention for the daily flow of greywater (i.e. double the daily flow).

For example: a three bedroom house reusing laundry water only.

The daily greywater volume is calculated as follows:

$$\begin{aligned}
 &= 4 \text{ persons @ } 42\text{L/person/day} \\
 &= \mathbf{168 \text{ litres daily greywater flow}}
 \end{aligned}$$

Therefore the capacity of tank required is:

$$\begin{aligned}
 &= 168\text{L} + 24 \text{ hour combined retention (i.e. double the daily flow)} \\
 \text{i.e. } &= 168\text{L} \times 2 \\
 &= 336\text{L } \mathbf{\text{tank capacity required}}
 \end{aligned}$$

**Note:** The size of the tank will need to be increased if spa baths are to be connected.



### 3.4.4 Sizing Irrigation Areas

Greywater irrigation systems are sized on whether they use sub-soil trench irrigation methods or drip/spray irrigation methods. Systems are sized on the capability of the soil to receive the greywater (i.e. the Loading Infiltration Rate [LIR]) and the estimated daily greywater flow.

The permeability of the soil is to be determined in accordance with the requirements of the *Health (Treatment of Sewage and Disposal of Effluent and Liquid Waste) Regulations 1974* (see Part 3, Table 5).

#### 3.4.4.1 Sub Soil Trench Irrigation Sizing

The size of the greywater irrigation trench is calculated using the following equation:

$$L = \frac{V}{\text{LIR} \times A}$$

Where:

**L** = length of trench in metres

**V** = daily greywater volume in litres/day

**LIR** = Loading Infiltration Rate in litres/metre<sup>2</sup>/day (related to permeability of the soil - see Table 5 below)

**A** = surface area of the trench in m<sup>2</sup> (i.e. the sides below the invert of the distribution pipe and base of the trench per lineal metre).

The infiltration rates for greywater flow are determined on the soil type as shown below in Table 5.

The loading infiltrative rate can be higher depending on whether the system has a diverter and/or has alternating trenches (i.e. two trenches that have a diverter box that can change the flow of greywater allowing one of the trenches to be shut off at any time). By diverting the flow of greywater or shutting off the irrigation area, the irrigation area can rest and dry out. This, rejuvenates the soil's ability to receive greywater.

If the system has no diverter and does not have alternative trenches a lower infiltrative rate must be used.



**Table 5: Standard Greywater Loading Infiltration Rates**

TIME FOR WATER TO FALL 25 mm** (minutes)	SOIL TEXTURE	LOADING INFILTRATION RATE (litres per m <sup>2</sup> per day)	
		System with diverter and/or alternating trenches	System with no diverter and non-alternating trenches
1 to 5	Sand	30	15
More than 5 to 60	Loams or gravels	20	10
More than 60	Impervious Clays	As approved by the Executive Director, Public Health.	

\*\*a procedure which measures soil permeability by recording the time taken for water in a 300mm x 300mm hole to fall 25mm, see Schedule 8 of the *Health (Treatment of Sewage and Disposal of Effluent and Liquid Waste) Regulations 1974* for a full explanation of the method.

See Appendix 2 for example calculations.

#### 3.4.4.2 Drip or Spray Irrigation Sizing

The required irrigation area size should be calculated on the basis of 10 litres/m<sup>2</sup>/day in sand and gravel/loam or for other soils in accordance with AS 1547:2000 – “*Onsite Domestic Wastewater Management*”.

It may be appropriate to engage a Irrigation Association of Australia, Certified Irrigation Designer to design the irrigation system to ensure the system is designed correctly.

#### 3.4.5 Reduced Sizing Allowances

##### 3.4.5.1 Reduced Lengths for Sub Soil Trenches

Sub-soil trench lengths may be **halved only** if the greywater system has a:

**OVERFLOW DEVICE**, allowing greywater to automatically overflow into the primary sewerage system should a blockage occur,

and

**MANUAL DIVERTER**, allowing the homeowner to divert the greywater to the primary sewerage system in rainfall periods.



The homeowner must also:

- Divert greywater back to the primary sewerage system (i.e. sewer, septic tank or ATU) in the wet season (e.g. winter months) to allow the soil to rest and rejuvenate.
- Plant out the irrigation trench to uptake the greywater.

If the house is regularly at full capacity or experiences peak flows the trench lengths should be calculated using the standard LIR as specified in Section 3.4.4.1.

To size the reduced trench length, calculate either using double the standard LIR (see Table 5) e.g. in sandy soils the trench length can be calculated using 60L/m<sup>2</sup>/day (i.e. LIR 30 x 2) or by calculating the trench length using the recommended LIR then halving the trench length.

The trench lengths for a 200mm x 200mm trench (infiltrative area = 0.6m<sup>2</sup>) using both the standard LIR or a higher LIR (i.e. LIR x 2) are as follows. Trench lengths calculated using the higher LIR are the minimum trench length allowed (for a 200mm x 200mm trench). The minimum lengths will change according the infiltrative area of the trench.

**Note: a reduced system does not apply to a one or two bedroom house. One and two bedroom homes should be sized using the standard LIR (see Table 5).**

One and two bedroom homes should be sized using the standard LIR or as a three bedroom home to allow for surge loadings in the irrigation trench.

**Table 6: Trench Lengths for a 200mm x 200mm trench using the standard LIR or a higher (double) LIR**

BEDROOM NUMBERS	TRENCH LENGTHS (METRES)						
	LIR (Loading Infiltrative Rate)	Bathroom only SAND	Laundry only SAND	Bathroom & Laundry SAND	Bathroom only GRAVEL/LOAM	Laundry only GRAVEL/LOAM	Bathroom & Laundry GRAVEL/LOAM
Up to 3 bedrooms (4 persons)	Higher	6m	5m	10.5m	8.5m	7m	15.5m
	Standard*	11m	9m	21m	17m	14m	31m
4 bedrooms (5 persons)	Higher	7m	6m	13m	11m	9m	19.5m
	Standard*	14m	12m	26m	21m	17.5m	39m
5 bedrooms (6 persons)	Higher	8.5m	7m	15.5m	13m	10.5m	23m
	Standard*	17m	14m	31m	25.5m	21m	46.5m

\*See Table 5 for standard loading infiltrative rates. Figures calculated using column one of Table 5.



### 3.4.5.2 Reduced Sizing Allowance for Dripper Systems

The irrigation area can be calculated using 20 litres/m<sup>2</sup>/day in sand and gravel/loam only if the system has an;

**OVERFLOW DEVICE**, allowing greywater to automatically overflow into the primary sewerage system should a blockage occur,

and

**MANUAL DIVERTER**, allowing the homeowner to divert the greywater to the primary sewerage system in rainfall periods.

### 3.4.5.3 Reduced Sizing Allowance for Septic Systems

If a greywater system does not have an overflow to the existing septic system, then the septic system may be reduced in accordance with Schedule 9 of the *Health (Treatment of Sewage and Disposal of Effluent and Liquid Waste) Regulations*.

If the greywater system has an overflow to the septic system then the greywater irrigation system may be reduced in size, but the septic system cannot be reduced in size and must be sized as an all waste (combined) system.

## 3.5 SITING A GREYWATER IRRIGATION SYSTEM

Once the greywater irrigation system has been correctly sized, identification of a suitable location for siting the system in the garden needs to be considered. It must be located to avoid damage to buildings, structures and adjoining properties. A range of minimum setback distances are necessary from drip/spray irrigation areas, tanks and subsoil irrigation trenches.

Greywater irrigation systems must be sufficiently distanced from environmental features or water supplies. Setback distances are given in Table 7.



**Table 7: Minimum Setback Distances**

Item	Drip Irrigation Area (metres)	Spray Irrigation Area (metres)	Subsoil Irrigation Trenches (metres)
Closed Fence Boundaries	0.3	0.5	0.5
Open Boundaries (i.e. open fence or no fence)	0.5	1.2	1.2
Buildings*	0.5	0.5	1.2
Sub-soil Drains	3.0	3.0	6.0
Bores (private)** intended for human consumption	30.0	30.0	30.0
Paths, drives, carports etc.	0.3	1.8	0.5
Public Water Supply Production Bores located in Public Drinking Water Source Areas***	100	100	100
Wetlands and water dependent ecosystems where the PRI is <5***	100	100	100

**Note:** Trench distance measured from edge of aggregate.

Drip distance measured from pipework.

Spray distance measured from edge of spray plume.

\* Greywater may contain chemicals that can damage your house if discharged against the foundations.

\*\* Only EDPH may vary this setback requirement.

\*\*\* For description of Public Drinking Water Supply Areas (PDWSA) or wetland positioning contact DOE. Greywater systems within 100 metres of a Priority 1 Drinking Water Source Protection Area must be approved by the DOE.

- All greywater irrigation systems (i.e. the dripper line or base of trench) must achieve a minimum of 500 mm clearance above the highest seasonal groundwater level. The “Perth Groundwater Atlas” is available on the Waters and Rivers Commission website at [www.wrc.wa.gov.au](http://www.wrc.wa.gov.au). The atlas enables an estimate to be made of the depth to groundwater beneath a property.
- Below ground greywater tanks must be a minimum of 1.2 metres from any boundary or building or structure.
- The site is required to have soil characteristics capable of receiving the greywater likely to be generated on the site without risk to public health or the environment. Sites that have shallow or no permeable topsoils, underlain by rock or low permeability soils (e.g. clays, etc.) are less able to receive greywater and may not be suitable for use.



- Trenches should be installed in a manner that ensures even distribution. For example, trenches must be laid level and constructed in such a manner that preferential flow to one portion of a trench will not occur.
- Where the land gradient is greater than 1:10 and it is practicable, the surface irrigation area may need to be modified by benching or bunding etc and/or increased in size to prevent runoff. If the land gradient is greater than 1:5 then the application will be individually assessed by the Local Government.
- Entry of excessive stormwater to a greywater irrigation area should be minimised via diversion drains.
- The irrigation area should be planted with appropriate grasses or other groundcover and shrubs that tolerate wet conditions and have a high evapotranspiration capacity. Ask your local garden centre for further information on plant species.

### **3.6 MATERIALS FOR IRRIGATION AREAS**

Drip irrigation pipework and fittings must comply with *AS 1477 – “PVC Pipes and fittings for pressure applications”* or *AS 2698.2 – “Perforated effluent pipe and associated fittings for sewerage applications”*.

The distribution pipe used in gravity fed sub-soil trenches should have a minimum internal diameter not less than 80mm in accordance with *AS 2439 – “Perforated plastic drainage and effluent pipe and fittings”*. A porous soakage hose is not acceptable for distribution of primary treated greywater in trench systems due to the likelihood of clogging.



## CONTACTS

### Department of Health

#### Wastewater Management Branch

Postal Address: PO Box 8172  
Perth Business Centre WA 6849  
Telephone: (08) 9388 4999  
Facsimile: (08) 9388 4910  
Website: [www.health.wa.gov.au](http://www.health.wa.gov.au)

Extra copies of the “Code of Practice for Greywater Reuse in Western Australia” are available online at [www.health.wa.gov.au/publications/](http://www.health.wa.gov.au/publications/).

### Water Corporation

Customer Correspondence: Locked Bag 2  
Osborne Park Delivery Centre WA 6916  
General Enquiries: Telephone: 13 13 85  
8am - 5pm weekdays  
Website: [www.watercorporation.com.au](http://www.watercorporation.com.au)

### Department of Environment

Postal Address: PO Box 6740  
Hay Street  
East Perth WA 6892  
Telephone: (08) 9278 0300  
Facsimile: (08) 9278 0301  
Website: [www.wrc.wa.gov.au](http://www.wrc.wa.gov.au)

Perth Groundwater Atlas is available online at [www.wrc.wa.gov.au/infocentre/atlas/atlas\\_html/](http://www.wrc.wa.gov.au/infocentre/atlas/atlas_html/).

### State Law Publishers

Street Address: Ground Floor  
10 William Street  
Perth WA 6000  
Telephone: (08) 9321 7688  
Website: [www.slp.wa.gov.au](http://www.slp.wa.gov.au)

*Health (Treatment of Sewage and Disposal of Effluent and Liquid Waste) Regulations 1974* are available online at [www.slp.wa.gov.au](http://www.slp.wa.gov.au).

### Our Water Future Website

Website: [www.ourwaterfuture.com.au](http://www.ourwaterfuture.com.au)

For information on being water wise, water restrictions, community events and news, options for our water future and planning for our water future.

Greywater Fact Sheet [www.ourwaterfuture.com.au/Factsheets/factsheet\\_greywater.asp](http://www.ourwaterfuture.com.au/Factsheets/factsheet_greywater.asp)



## REFERENCES

Christova-Boal D, Lechte P, Shipton R (1995). "Installation and Evaluation of Domestic Greywater Reuse Systems". Department of Civil and Building Engineering, Victoria University of Technology, Victoria, Australia.

Department of Health, Western Australia. "*Treatment of Sewage and Disposal of Effluent and Liquid Waste Regulations*" 1974.

(available from: [www.slp.wa.gov.au](http://www.slp.wa.gov.au))

Department of Health, Western Australia (2001). "*Code of Practice for the Design, Manufacture, Installation and Operation of Aerobic Treatment Units (ATUs) Serving Single Dwellings*".

Jeppersen, B and Solley, D (1994). "Domestic Greywater Reuse: Overseas Practice and its Applicability to Australia". Research Report No 73. Urban Research Association of Australia, Brisbane City Council.

Jeppersen, B and Solley, D (1996). "Model Guidelines for Domestic Greywater Reuse for Australia". Research Report No 107. Urban Research Association of Australia, Brisbane City Council.

(available from: [www.wsaa.asn.au](http://www.wsaa.asn.au))

Patterson, R.A. Laundry Products Research, summary paper on website ([www.lanfaxlabs.com.au](http://www.lanfaxlabs.com.au))

Patterson, R.A. (1999). *Reuse Initiatives Start in the Supermarket*. NSW Country Convention. Institution of Engineers Australia. 6-8 August 1999. Northern Group, Institution of Engineers Australia, Armidale.

Patterson, R.A. (2000). *Water Quality Relationships with Reuse Options*. in 3rd International Symposium on Waste Water Reclamation, Recycling and Reuse. 3-5 July 2000. Paris France. International Water Association. Preprint Book 8, pp 205-212.

Standards Australia (2000). AS 1547:2000 – "*Onsite Domestic Wastewater Management*".

Standards Australia (1998). AS 1546.1:2000 – "*Onsite Domestic Wastewater Management – Septic Tanks*".

US Environmental Protection Agency (1992). "Guidelines for Water Reuse". USEPA pp. 81-88.



## BIBLIOGRAPHY

Californian Department of Water Resources (1995). “Using Graywater in your home landscape - the Graywater Guide”. State of California.  
(available from: [www.dpla.water.ca.gov/urban/land/graywater\\_guide\\_book.pdf](http://www.dpla.water.ca.gov/urban/land/graywater_guide_book.pdf))

Kourik, R (1993). “Gray Water Use in the Landscape: how to help your landscape prosper with recycled water”. Metamorphic Press, California.

Ludwig, A (2000). “Create an Oasis with Greywater: Your complete guide to choosing, building and using Greywater systems”. 4<sup>th</sup> Edition, Oasis Design, Santa Barbara, CA

NSW Department of Health (2000). “Greywater Reuse in Sewered Single Domestic Premises”, Sydney.  
(available from: [www.health.nsw.gov.au/public-health/ehb/general/wastewater.html](http://www.health.nsw.gov.au/public-health/ehb/general/wastewater.html))

Van Dok, W (2000). “The Water-efficient Garden: includes detailed information on greywater irrigation”. Water-efficient Gardenscapes, Victoria, Australia  
(available from: [home.nemesis.com.au/water](http://home.nemesis.com.au/water))



## APPENDIX 1

### GUIDELINES FOR THE BUCKETING OF GREYWATER

#### Guidelines for Bucketing Household Greywater

##### What is greywater?

Greywater is household wastewater that has not come into contact with toilet waste. It comes from the bath, shower, bathroom wash basins, clothes washing machine, and laundry trough. Wastewater from the kitchen sink and dishwasher should not be reused as these can contain heavy loads of organic material, fats and caustic additives. If possible, only the rinse water from washing machines should be reused.

Note: Water from domestic air conditioners is not greywater, and the Department of Health has no objections to its reuse on gardens.

##### Why reuse greywater?

Western Australia is experiencing water restrictions due to current drought conditions and the critically low levels of surface water storage. It is recognised that in times such as these many householders like to conserve water by reusing their greywater.

For long term sustainable greywater reuse, greywater should be disposed of below ground in a manner approved by the Department of Health, as required under the current legislation. This is because greywater can contain disease causing organisms, detergents, soaps, nutrients, oils, salts and particles of hair, food, lint, etc. Unless properly managed, these characteristics can give rise to health risks and degradation of the environment.

In the current circumstances, there is nevertheless considerable public interest in greywater reuse where facilities for below ground application are not available. The Department has therefore provided this advice for minimising the health risk of above ground application, which should only be by bucket or similar receptacle.

##### How can I reuse greywater?

Greywater from the bath, laundry trough and hand basin are the most readily available sources of greywater that can be reused. By using a bucket, greywater can be collected and applied to garden or lawn areas. This manual application will assist in keeping health risks to a minimum.

If the house is serviced by reticulated sewerage, it is important not to reuse all the greywater from the household. Some greywater is needed to help flush sewer pipes to prevent blockages.



### The do's

- Select garden friendly detergents. Only biodegradable products and products with low phosphorus, sodium, boron, chlorine and borax should be used. Bleaches and fabric softeners should be used sparingly.
- Apply greywater in several locations rather than one single point, so that pooling of greywater does not occur.
- Apply greywater to areas that are not readily accessible to children and household pets.

### The don'ts

- Don't use greywater from the washing of nappies and soiled clothing.
- Don't use greywater when a household resident has an infectious disease such as diarrhoea, infectious hepatitis, intestinal parasites, etc.
- Don't discharge greywater on edible plants or where fruit fallen to the ground is eaten.
- Don't store greywater. Stored greywater will turn septic giving rise to offensive odours and provide conditions for micro-organisms to multiply.
- Don't let your greywater go beyond your property and cause a nuisance for your neighbours.
- Don't over water. Over application of greywater may clog the soil causing the pooling of greywater, which can result in the development of unsightly areas of grey/green slime. This slime is caused by the presence of soaps, shampoos, detergents and grease in greywater. The accumulation of slime can cause odours, attract insects and cause environmental damage.

**Note:** Plants of the Proteaceae family evolved in low phosphorus soils and are therefore susceptible to excess phosphates. These plants are not really suited to greywater reuse and include grevillea, hakea and banksia. Shade loving and acid loving plants do not like the alkalinity of greywater. These include azaleas, camellias, gardenias, begonias, and ferns.

The detergents in greywater will initially reduce the non-wetting characteristic of the soil however, over time when detergents dry on the ground surface the non-wetting characteristics of the soil will increase. It is important to flush areas with fresh water and regularly monitor whether the soils are non-wetting.



## APPENDIX 2

### EXAMPLES OF GREYwater CALCULATIONS

A house has 5 bedrooms. The soil type is sand. All greywater is to be reused. Calculate the minimum area required to irrigate the greywater via sub-soil trench irrigation and drip or spray irrigation.

#### 1. Calculate the daily greywater flow

Daily greywater flow for a 5 bedroom house is calculated as follows:

1. Calculate the number of occupants based on the number of bedrooms.  
(2 persons for the first bedroom, 1 person per each additional bedroom)  
 $2 \text{ persons} + 1 \text{ persons} + 1 \text{ persons} + 1 \text{ persons} + 1 \text{ persons} = 6 \text{ persons}$
2. Calculate the daily flow per person based on figures given in Part 3, Section 3.4.2.  
(117L/person based on kitchen, laundry and bathroom flows)  
 $6 \text{ persons} @ 117 \text{ Litres/day} = \text{Total Daily Greywater Flow (V)} = 702\text{L/day}$

#### 2 (a). Calculate the area of land required to reuse greywater via a Sub-Soil Trench

The required length of an alternating subsoil trench irrigation system with dimensions of 250mm (depth) x 300mm (width) to reuse 702L/day is calculated using the following formula (see Part 3, Section 3.4.3):

$$L = \frac{V}{\text{LIR} \times A}$$

- i) Calculate the surface area (**A**) of the 250mm x 300mm trench per lineal metre length.

$$A = [0.25\text{m (side)} + 0.30\text{m (bottom)} + 0.25\text{m (side)}] \times 1\text{m} = 0.80\text{m}^2$$

- ii) Using the standard Loading Infiltration Rate (**LIR**) for sand, 30 Litres/m<sup>2</sup>/day, (taken from table 5). Calculate the required trench surface area (**L**) to reuse the daily greywater flow, (**V**) 702L.



$$L = \frac{702\text{L/day}}{(30 \text{ Litres/m}^2/\text{day}) \times (0.80\text{m}^2)}$$

L = 29 metres i.e. 4 x 7.25 metre or 2 x 14.5 metre (250mm x 300mm) trenches  
∴ the total area of land required is approximately 8 metres x 5 metres or any other configuration

**2 (b). Calculate the reduced length of a sub-soil irrigation trench (NB: only if the greywater system is in accordance with Part 3, Section 3.4.5)**

Use the above method (2a) to calculate the length of trench required i.e. 29 metres.

Now divide the trench length in half

$$29 \text{ metres} \div 2 = 14.5 \text{ metres}$$

∴ trench length required = 14.5 metres.

**3. Calculate the area of land required to reuse greywater via a drip or spray irrigation**

Using the figure 10L/m<sup>2</sup>/day in Part 3, Section 3.4.4.2.  
 $702\text{L/day} \div 10\text{L/m}^2/\text{day} = 70.2\text{m}^2$  required



## APPENDIX 3

### PRIMARY TREATMENT SYSTEMS

Three options for primary treatment systems are listed below:

**Note:**

*Greywater systems in sewered locations must have a diverter and a Water Corporation authorized overflow device fitted with a backflow prevention device (see Part 3, Section 3.1).*

*All primary greywater systems are to incorporate below ground irrigation methods.*

#### 1. Diversion Devices

A diversion device is a hand activated switch that diverts filtered greywater by gravity or pump directly to a sub-soil irrigation trench. A diversion device incorporates an overflow device, filter and a hand activated valve, switch or tap which is fitted to the outlet of the waste pipe of the plumbing fixture such as a laundry tub. The filter system generally requires regular maintenance by the homeowner.

The basic requirements of diversion devices are listed below:

- The design must include an automatic overflow (to the sewer or primary sewerage system) which occurs when the filter becomes clogged or the irrigation system fails. A hand activated diverter switch must be installed to divert the greywater.
- Approval from the Department of Health is required prior to systems being manufactured for sale or use.
- Greywater diversion valves must be designed and constructed in accordance with ATS 5200.460 – 2004 – Australian Technical Specification: Technical Specification for plumbing and drainage products – Part 460: Grey water diversion valve assembly.

#### 2. Sedimentation tank with sub-soil trench irrigation

The basic requirements are listed below:

- The sedimentation tank must comply with the *Health (Treatment of Sewage and Disposal of Effluent and Liquid Waste) Regulations 1974* or as approved by the EDPH.
- Where a pump is used to distribute greywater after treatment in the sedimentation tank, the pump tank must:
  - comply with *AS 1546.1 – “Septic Tanks”* ;
  - have a minimum capacity of 250L where fitted with an overflow device or 250L plus a minimum of one days reserve capacity where a overflow is not fitted;



- be fitted with a high water level warning device prior to overflow and before the 250 litre level; and
  - have an inspection opening and manhole access opening.
- Sludge build up in the sedimentation tank should be pumped out at least every 5 years.
- Sub-soil trench systems must be constructed in accordance with AS 1547:2000 – “*Onsite Domestic Wastewater Management*” or a DOH approved design. Note: the minimum permitted trench depth below surface is 100mm and the base should not exceed 400mm below ground surface.
- Sub-soil trench lengths must be designed in accordance with Section 3, Part 3.4.4.1 based on the surface area of the irrigation trenches and the permeability of the receiving soil.

### **3. Conversion of disused septic tank systems to a primary greywater system**

The conversion of disused septic systems to a sedimentation tank and sub-soil greywater irrigation system is permitted subject to the following:

- The septic tank must be completely emptied out, including gross solid particles, by an approved liquid waste contractor. The Local Government may require a receipt of septic pump out as proof of completion.
- The existing drainage receptacles (e.g. soak wells or leach drains) must be replaced with below ground irrigation trenches, i.e. greywater disposal is not considered reuse. The base of the trench should not exceed 400mm below the finished ground surface.



## APPENDIX 4

### SECONDARY TREATMENT SYSTEMS

One option for a secondary treatment system that collects, treats and disinfects greywater to a standard of 20 mg/L BOD<sub>5</sub>, 30 mg/L SS and 10 thermotolerant coliforms/100mL prior to irrigation via drip and/or surface irrigation methods is detailed below.

#### **Conversion of Aerobic Treatment Units (ATU) systems to greywater systems**

The conversion of disused ATUs to greywater systems is permitted subject to the following:

- The ATU is to be installed, operated and maintained in accordance with the *“Code of Practice for the Design, Manufacture, Installation and Operation of Aerobic Treatment Units Serving Single Dwellings”*, November 2001.
- The effluent quality prescribed for ATUs must continue to be maintained.
- Desludging of ATUs to allow conversion is not necessary.
- If installed in a sewerred area the system must have a sewer overflow and backflow prevention devices fitted approved by the DOH and Water Corporation.



## APPENDIX 5

### SUB-SOIL TRENCH IRRIGATION

The following are examples of approved sub-soil trench irrigation methods taken from AS 1547:2000 – “*Onsite Domestic Wastewater Management*”. These designs are suitable for greywater irrigation provided they are constructed in accordance with the standard AS 1547:2000 – “*Onsite Domestic Wastewater Management*”.

**Figure A5: 1 – Self Supported Arch**

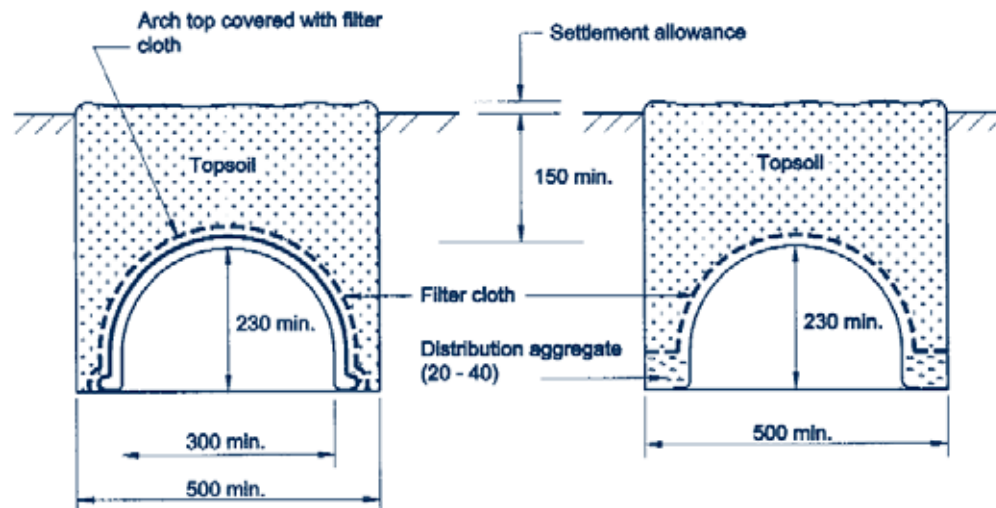
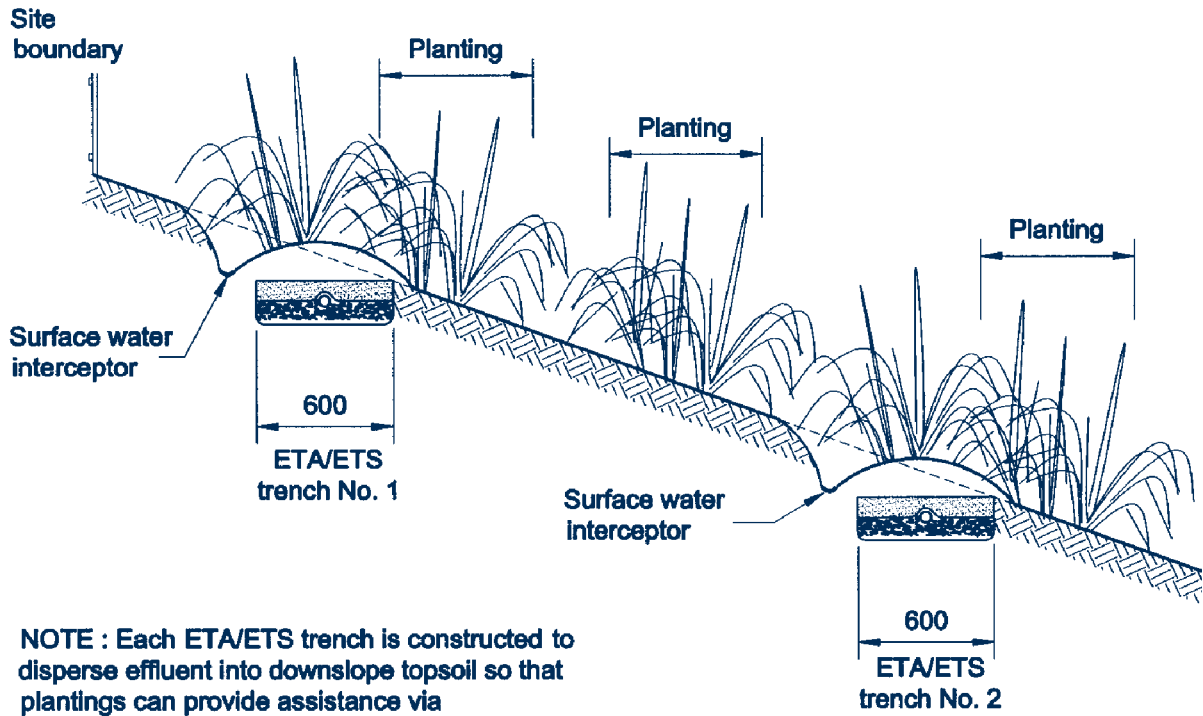



Figure A5: 2 – Evapo-transpiration-absorption (ETA) trench/Evapo-transpiration-seepage (ETS) trench



NOTE : Each ETA/ETS trench is constructed to disperse effluent into downslope topsoil so that plantings can provide assistance via evapo-transpiration.

Figure A5: 3 – ETA/ETS Bed

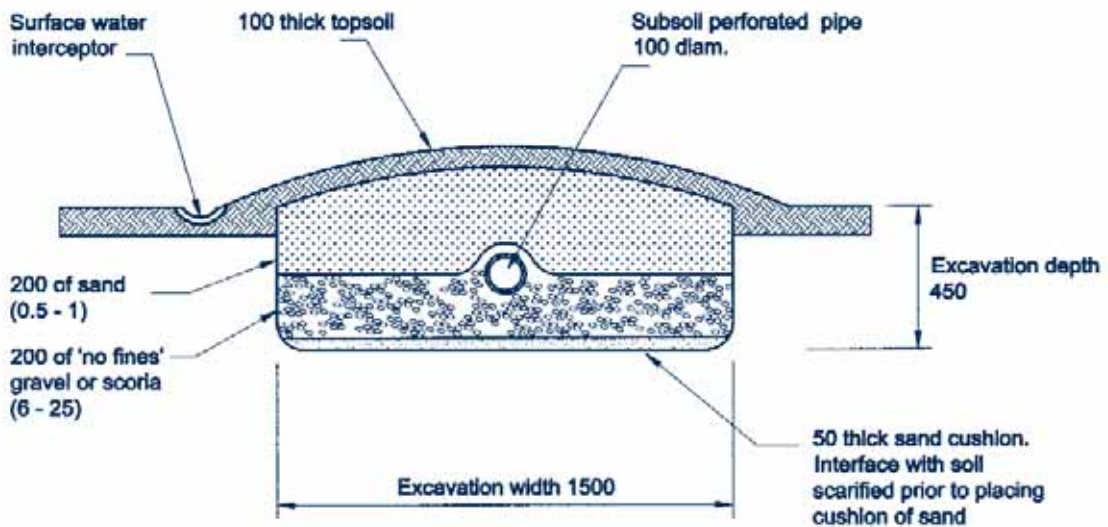



Figure A5: 4 – Conventional Piped Trench

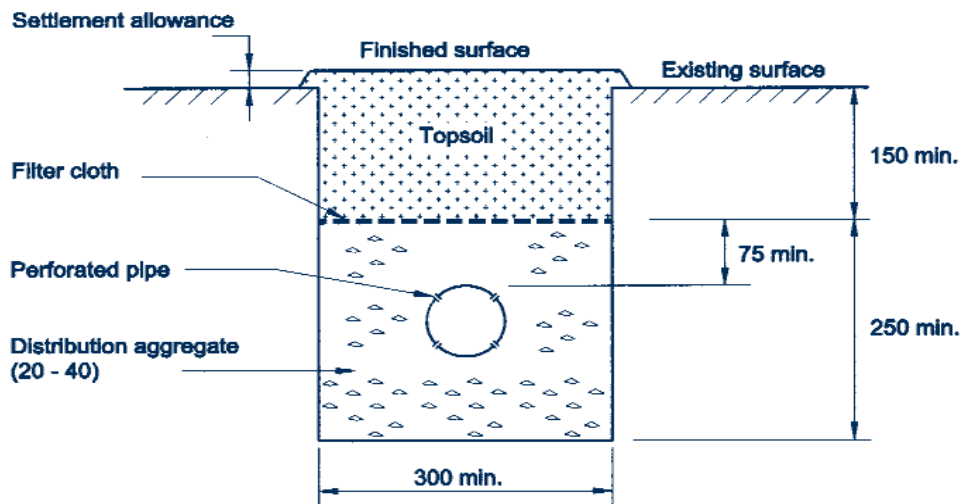

Figure A5: 5 – Conventional Bed

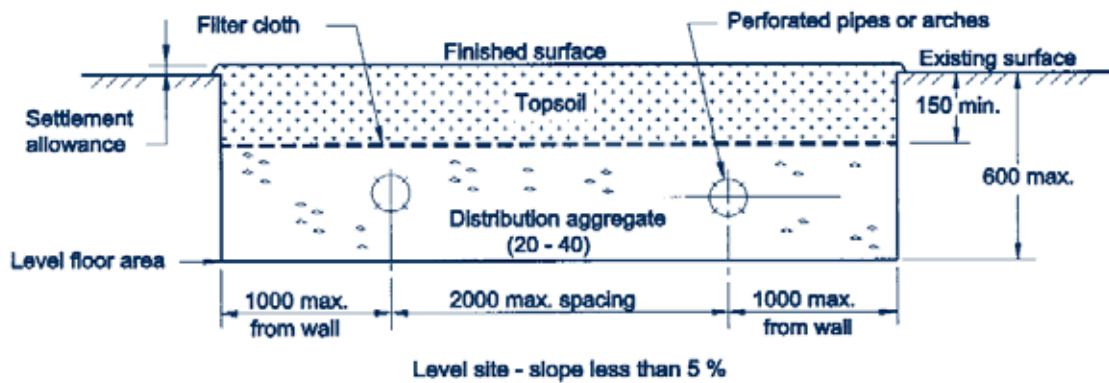
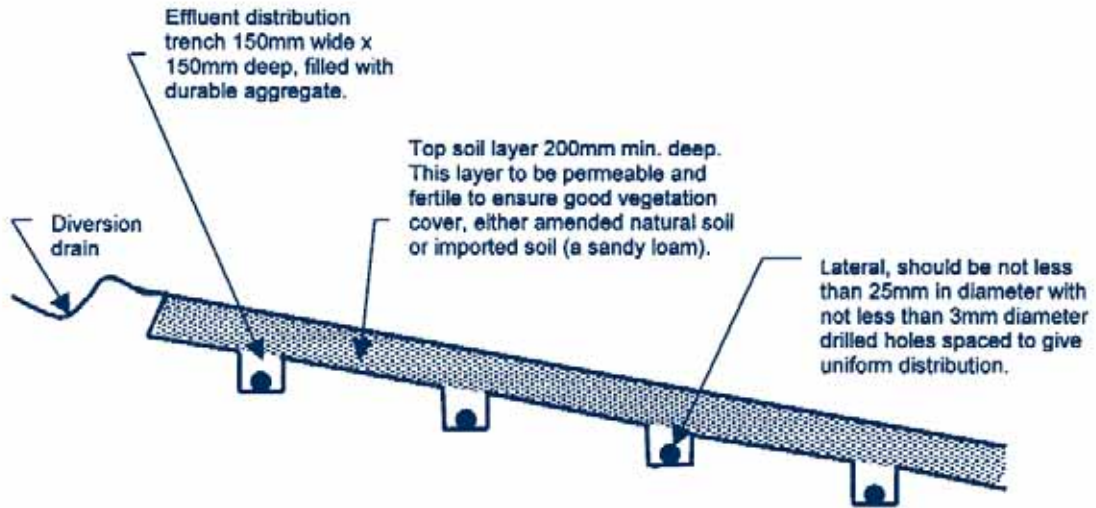
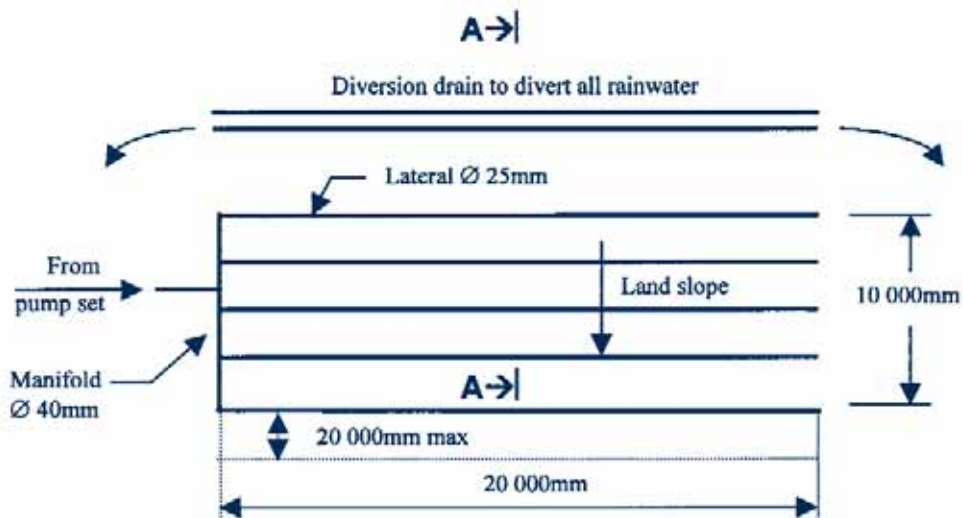



Figure A5: 6 – Typical layout of sub-surface irrigation



a) Typical sub-surface irrigation cross section A-A



b) Typical plan layout of manifolds and laterals for a sub-surface irrigation area of 200m<sup>2</sup>



*This page is intentionally left blank*



*This page is intentionally left blank*



Department of Environment  
Department of Health