

Application to Construct a Front Fence

PRIVATE PROPERTY LOCAL LAW 1998

A person must not without the City of Wanneroo Approval erect a freestanding fence of non-masonry construction, greater than one meter in height within six meters from their front boundary.

PROPERTY PARTICULARS

LOT _____ HOUSE _____

STREET _____

SUBURB _____ POSTCODE _____

OWNERS DETAILS

NAME _____

ADDRESS _____

SUBURB _____ POSTCODE _____ PHONE _____

APPLICANT DETAILS

NAME _____

ADDRESS _____

SUBURB _____ POSTCODE _____ PHONE _____

- 1) AN APPLICATION TO CITY IS ONLY REQUIRED WHEN THE FRONT FENCE IS PROPOSED TO EXCEED ONE METRE IN HEIGHT.
- 2) WHEN A FENCE EXCEEDS 1.2 METRES IN HEIGHT IT IS REQUIRED TO BE VISUALLY PERMEABLE.

NOTE: THIS ONLY APPLIES TO FRONT FENCES – FENCES ON SECONDARY STREETS & DIVIDING FENCES CAN BE SOLID TO A MAXIMUM HEIGHT OF 1.8 METRES.

THIS APPLICATION IS TO BE ACCOMPANIED BY:

- Two Copies of Site plans drawn to a scale of not less than 1:200 indicating existing structures, ground levels and proposed positioning of the front fence.
- Two copies of Construction Specifications indicating Size, Materials, Driveway Truncations and Footing details.
- Building Licence Application fee - \$85.00
- Builders Registration Board Disputes Levy - \$40.50

Owners
Signature: _____ Date: ____ / ____ / ____

SITE PLAN

TO BE DRAWN AT SCALE 1 : 200

NOTE :-

SIGHTLINES AT VEHICLE ACCESS POINTS

(1) Fences adjacent to vehicle access points shall be truncated with the minimum dimension of the truncation being 1.5m or the fence reduced in height to no more than 0.75m.

(2) Sub-clause (1) does not apply-

(a) to a fence which is an open fence that does not obscure the lines of vision of a motorist using the access point, or

(b) where there is a distance of 3.5m between the fences and a carriageway or footpath.

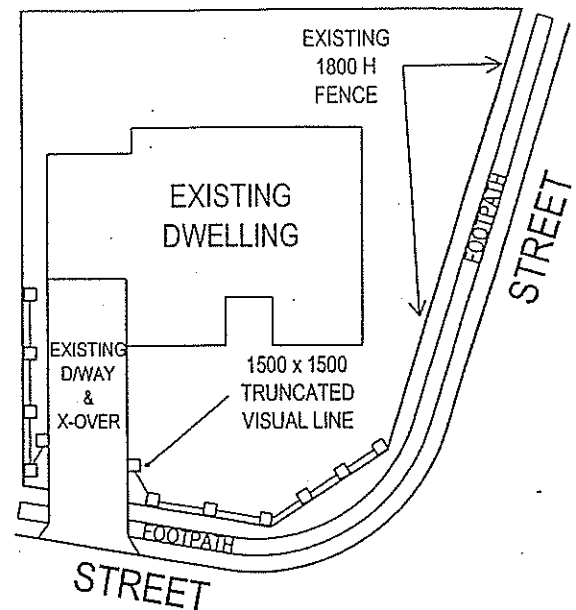

SECTION

SCALE - AS REQUIRED

TYPICAL PIER DETAIL

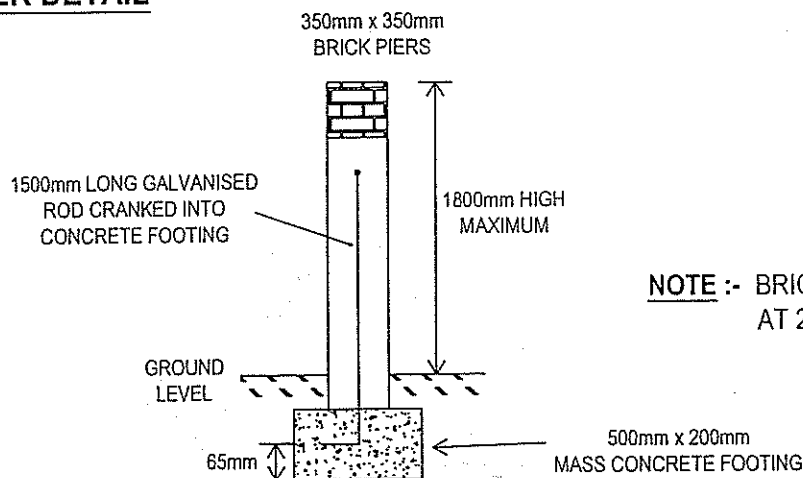

NOTE :- BRICK PIERS TO BE CENTRED AT 2700mm APART.

ELEVATIONS - COMPOSITE FENCING

SCALE - AS REQUIRED

EXAMPLES OF ACCEPTABLE TYPES OF INFILL PANEL FENCING

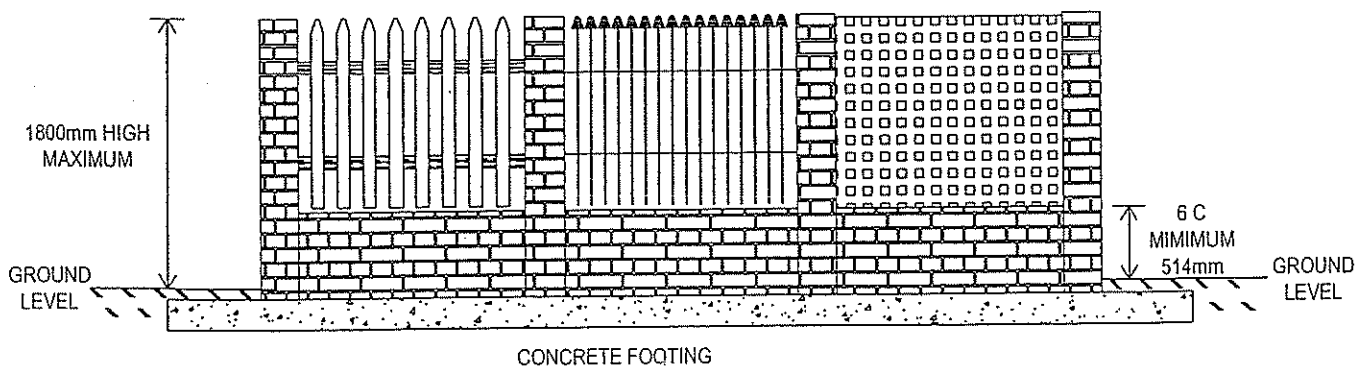

City of
Wanneroo

FRONT FENCE INFORMATION

DATE : 5th September 2001