

Revision notes:		
Rev.	Date:	Notes:
A	03/06/2020	IFA

Drawn by: JT	Client: TBA
-----------------	----------------

Project: PATIO - 46 LANCEWOOD STREET	Drawing Title: SITE LAYOUT
---	-------------------------------

Date: 03/08/2020	Scale @ A3: 1:200
Revision: A	

**MR. TINH QUOC TRAN**  
 MScE, BEng, IMarEST, MIEAust  
 EA Registration # 5213670  
 5 Cluborne Vista, Success, WA 6164  
 quoc.tinh076@gmail.com  
 0410164722



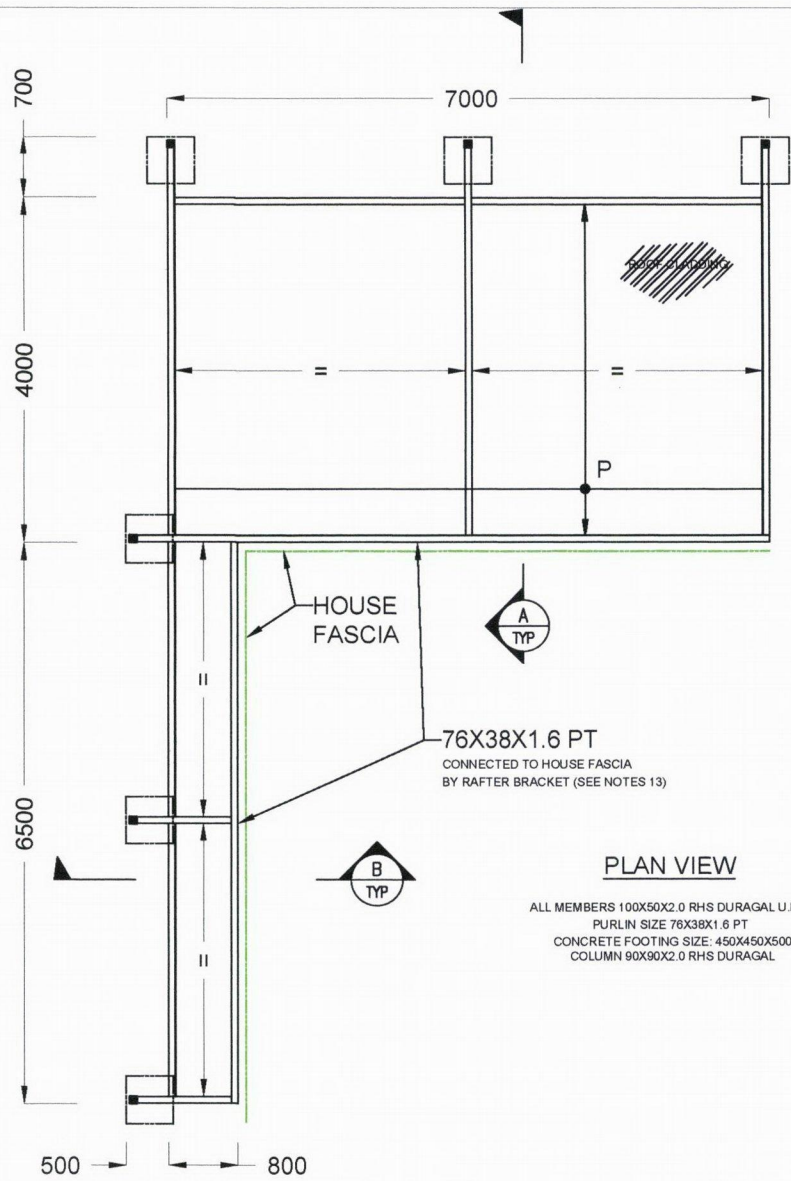

**PLAN VIEW**

ALL MEMBERS 100X50X2.0 RHS DURAGAL U.N.O  
 PURLIN SIZE 76X38X1.6 PT  
 CONCRETE FOOTING SIZE: 450X450X500  
 COLUMN 90X90X2.0 RHS DURAGAL

Revision notes:		
Rev:	Date:	Notes:
A	03/06/2020	IFA

Drawn by: JT	Client: TBA
-----------------	----------------

Project PATIO - 46 LANCEWOOD STREET	Drawing Title: GENERAL ARRANGEMENT
--	---------------------------------------

Date: 09/09/2020	Revision: A
Scale @ A3: NTS	

**MR. TINH QUOC TRAN**  
 MScE, BEng, IMarEST, MIEAust  
 EA Registration # 5213670  
 5 Claiborne Vista, Success, WA 6164  
 quocinh076@gmail.com  
 0410164722

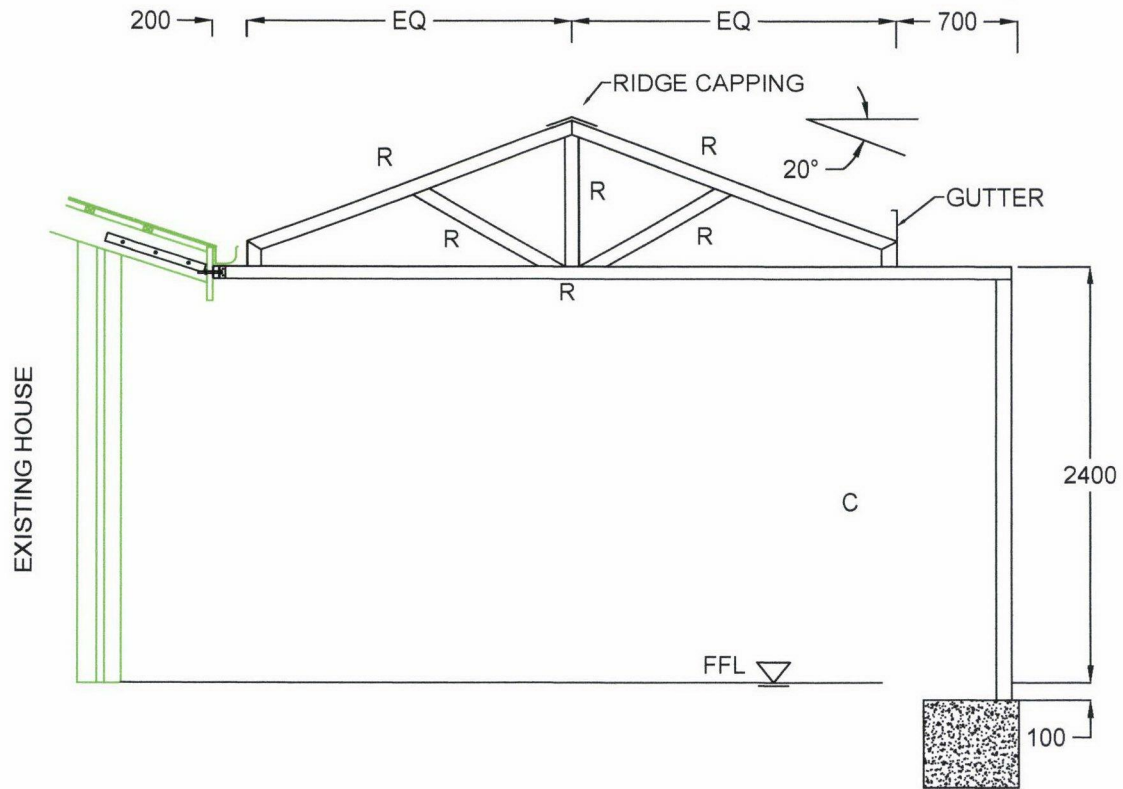

**SECTION A**  
FFL = HOUSE FFL

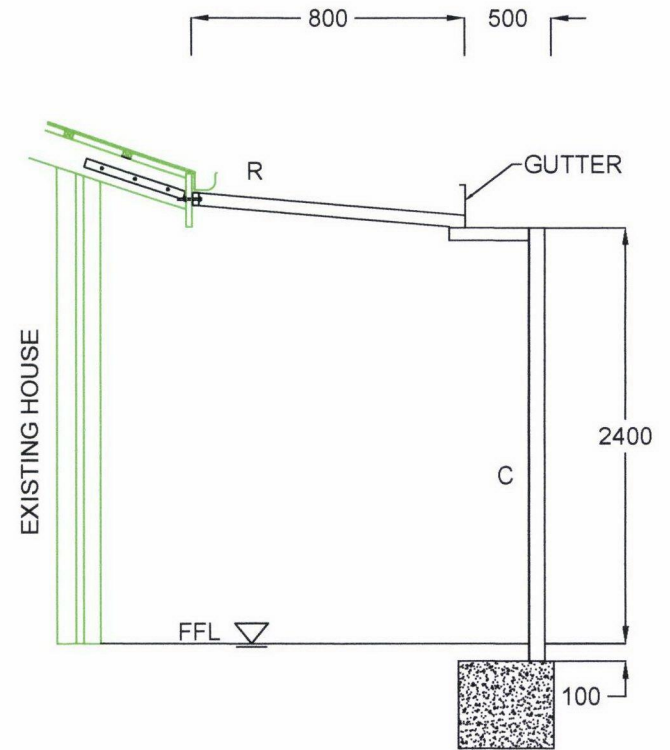

**SECTION B**  
FFL = HOUSE FFL

Revision notes:		
Rev.	Date:	Notes:
A	03/06/2020	IFA

Drawn by: JT	Client: TBA
-----------------	----------------

Project: PATIO - 48 LANCEWOOD STREET	Drawing Title: ELEVATION
---	-----------------------------

Date: 03/06/2020	Scale @ A3: NTS
Revision: A	

**MR. TINH QUOC TRAN**  
 MScE, BEng, IMarEST, MIEAust  
 EA Registration # 5213670  
 5 Claiborne Vista, Success, WA 6164  
 quocinh076@gmail.com  
 0410164722